

TRIUMPH

**REPLACEMENT
PARTS
CATALOGUE**

FOR 1974

BONNEVILLE 750 T140V

TIGER 750 TR7RV

SERIES I

INTRODUCTION

The Triumph Engineering Co. Ltd. point out that the information in this catalogue was complete and correct at the time of printing. Distributors will be informed of any subsequent alterations.

ENGINE AND FRAME NUMBERS

The engine number is located on the left side of the engine, immediately below the cylinder barrel to crankcase flange.

The frame number is located on the left side of the frame headlug, beneath the fork top lug and forward of the gasoline tank.

Both the engine and frame number should be quoted in full in any correspondence relating to the machine.

©

COPYRIGHT

All rights reserved. No part of this publication may be reproduced without permission.

INDEX

	<i>Page</i>		<i>Page</i>
AIR CLEANER	63	KICKSTARTER	37
ALTERNATOR	9, 41	MANIFOLD	17
AUTO-ADVANCE UNIT	31	MOTOR PLATES	47
BATTERY CARRIER	79	MOTOR TORQUE STAY	47
BRAKE SWITCH	45	MUFFLERS	49
BREATHER PIPES	43	OIL PUMP	15
CAMSHAFT, INLET AND EXHAUST	9	OIL PIPES	43
CARBURETOR	27, 29	OIL PRESSURE RELEASE VALVE ...	15
CENTRE STAND	43	PISTONS	9
CHAINS	41	PROP STAND	
CHAINCASE	41	PUSH RODS	19, 21, 23, 25
CLUTCH	39	REAR WHEEL	59
CLUTCH LEVER ASSEMBLY ...	37	RECTIFIER	77
COIL	77	ROCKERS	19, 21, 23, 25
CONDENSERS	77	SIDE PANEL	63
CONNECTING RODS	9	SPARK PLUG	77
CONTACT BREAKER	31	SPEEDOMETER	75
CONTROL CABLES	71	SPEEDOMETER GEARBOX	59
CONTROL LEVERS	69	SUSPENSION UNITS	45
CRANKCASE	11, 13	SWINGING FORK	45
CRANKSHAFT	9	SWITCHES	45, 69
CYLINDERS	19, 21, 23, 25	TABLE OF STANDARD HARDWARE	80, 81
CYLINDER HEAD	19, 21, 23, 25	TACHOMETER	75
EXHAUST PIPES	49	TACHOMETER GEARBOX	75
FENDERS	65	TAIL LAMP	67
FLASHERS	79	TAPPETS	17
FOOTRESTS	47	TIMING GEARS	9
FRAME	43	TOOLKIT	73
FRONT BRAKE	57	TWIN SEAT	61
FRONT FORKS	51, 53	VALVES	19, 21, 23, 25
FRONT WHEEL	55	VALVE GUIDES	19, 21, 23, 25
GAS TANK	61	WIRING HARNESS	79
GEARBOX	33, 35, 37	ZENER DIODE	77
HANDLEBAR	69		
HEADLAMP	79		
HORN	77		

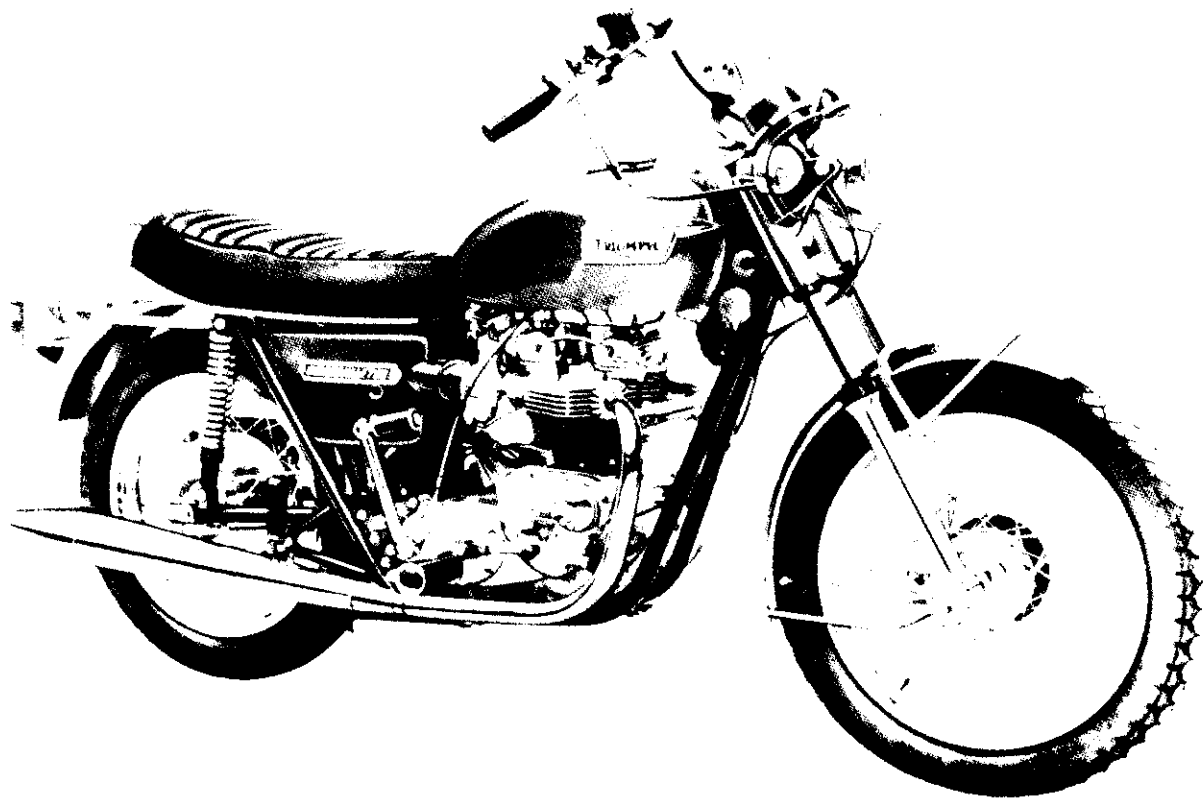

BONNEVILLE 750 (T140V), TIGER 750 (TR7RV) TECHNICAL DATA

		TR7RV	T140V
Compression ratio	...	8.25 : 1	8.25 : 1
Spark plugs	...	Champion N3	Champion N3
Carburetor	...	Amal Concentric 930	2 Amal Concentric 930
	Main jet	280	210
	Needle jet	-106	-106
	Throttle valve	No. 3½	No. 3
Gearbox sprocket	...	20 teeth	20 teeth
Chains	Front	⅜ Triplex x 84 links	⅜ Triplex x 84 links
	Rear	⅝" x ⅜" x 107 links	⅝" x ⅜" x 107 links
Capacities	Gas Tank	3.6 U.S. galls.	3.6 U.S. galls.
	Oil Tank	4.8 U.S. pints	4.8 U.S. pints
	Gearbox	⅞ pint (500 c.c.)	⅞ pint (500 c.c.)
	Primary Chaincase	¼ pint (150 c.c.)	¼ pint (150 c.c.)
	Front Forks (each leg)	⅓ pint (190 c.c.)	⅓ pint (190 c.c.)
Tire size	Front	3.25 x 19	3.25 x 19
	Rear	4.00 x 18	4.00 x 18

HOW TO USE THIS SPARE PARTS CATALOG

First consult the index on Page 3 for the parts or group of parts which you wish to locate. When you have located the parts make sure from the end columns that the part you have located does apply to your machine.

List the quantities required as single units; do not ask for "2 pairs" or "3 dozen".

In case of painted items always state the color required. Painted parts are available only in the colors or alternatives specified for that model of that particular year.

PLEASE NOTE

THROUGHOUT THIS LIST, ASSEMBLIES ARE PRINTED IN CAPITALS AND THE COMPONENTS INCLUDED IN THAT ASSEMBLY ARE INDENTED IN THE DESCRIPTION COLUMN, REVERTING TO THE ORIGINAL ALIGNMENT WHEN THE ASSEMBLY IS COMPLETE. TO ORDER THE COMPLETE ASSEMBLY IT IS NECESSARY ONLY TO QUOTE THE ASSEMBLY NUMBER. ANY COMPONENT PARTS LISTED MAY ALSO BE OBTAINED SEPARATELY IF REQUIRED.

SPECIAL WORKSHOP TOOLS

A COMPLETE LIST OF WORKSHOP TOOLS CAN BE MADE AVAILABLE BY EITHER CONTACTING YOUR DEALER OR APPLYING DIRECT TO THE TRIUMPH SERVICE DEPARTMENT. IN MOST CASES THESE TOOLS ARE VERY COSTLY AS THEY ARE MADE ENTIRELY FOR WORKSHOP USE, AND THEREFORE, IT IS NOT RECOMMENDED THAT THE PRIVATE OWNER PURCHASES THE TOOLS IN ORDER TO AID SERVICING THE MACHINE ONCE OR TWICE ONLY. IN THESE CIRCUMSTANCES IT IS FAR MORE ECONOMICAL TO GET IN TOUCH WITH A RECOGNISED DEALER.

UNIFIED THREAD FORM

NEW PARTS HAVING THREADED FIXINGS INTRODUCED IN THIS CATALOG HAVE THE UNIFIED FORM OF SCREW THREADS. THIS CHANGEOVER WILL BE CONTINUED AS AND WHEN NEW PARTS ARE INTRODUCED. EVEN WHERE PARTS ARE SIMILAR IN APPEARANCE NEW PART NUMBERS WILL BE ALLOCATED TO IDENTIFY THE UNIFIED THREADS. ALL NUTS, BOLTS AND STUDS HAVING THIS THREAD ARE IDENTIFIED BY MARKINGS. BOLTS HAVE A CIRCULAR RECESS IN THEIR HEADS, STUDS A CIRCULAR GROOVE ON THE END, AND NUTS HAVE INTERLOCKING CIRCLES ON THE SIDE.

COLOR

BONNEVILLE 750

Fenders - Chrome.
Gas tank - Cherokee Red/Ice White
Side covers - Black.

TIGER 750:

Fenders - Chrome
Gas tank - Sea Jade/Ice White
Side covers - Black.

TRIUMPH SPARES

HOW TO ORDER. Every part is indicated by a number, and this should be quoted together with the description. In order to assist customers, dimensions have been given in many cases where parts are similar. Parts where possible have been listed in order of assembly and a number of the illustrations show the assembly order also. With these aids, there should be no difficulty in identifying the parts you require.

ALWAYS HEAD YOUR ORDER WITH THE ENGINE NUMBER, STAMPED ON THE LEFT SIDE OF THE ENGINE JUST BELOW THE CYLINDER, TOGETHER WITH THE PREFIX LETTERS.

WHERE TO OBTAIN. Triumph Spare Parts can only be obtained from an authorised Triumph Dealer, and we recommend our customers to place their orders with the Triumph Dealer in their district. When parts not usually asked for are required, and for which the Dealer may have to write or obtain specially, the postage or carriage incurred becomes payable.

TRIUMPH SPARES ARE NOT SUPPLIED TO PRIVATE OWNERS DIRECT FROM THE FACTORY. A LIST OF AUTHORISED DEALERS WHO STOCK TRIUMPH SPARES IS AVAILABLE ON REQUEST. IF DIFFICULTY IS EXPERIENCED IN OBTAINING THE REQUIRED PARTS, THE MATTER SHOULD BE TAKEN UP DIRECTLY WITH THE TRIUMPH SPARES DEPARTMENT.

Customers are warned against the risk incurred by purchasing parts that are not of genuine Triumph manufacture. This risk is eliminated if parts are ordered as instructed from recognised Dealers.

PATTERNS AND PARTS FOR REPAIR. It is not necessary to send patterns if the part number is quoted. The sending of patterns often delays the order as parcel post or rail takes longer than letter post.

Parts sent to Coventry for repair, replacement, or as patterns should bear the sender's Name and Address and clear instructions should accompany the parts. In your own interest send a copy of the advice note under separate cover. All parts must be forwarded carriage paid and care should be taken to ensure that all remittances are sent separately and not enclosed with the parts. Fragile units such as cylinders, etc., should always be boxed to avoid damage in transit. Complete machines should have all fittings such as windscreens, driving mirrors, tools, etc., removed by the sender before despatch, as it is impossible for us to accept responsibility in the event of loss in transit. We are always pleased to give estimates for overhauling and repairs, but should an estimate not be accepted, a charge will be made covering cost of dismantling and re-assembling, if carried out. Work cannot be accepted at the factory direct from private owners.

Communications relating to Parts should be addressed to the SPARES DEPARTMENT and for repairs, guarantee claims and technical advice to the SERVICE DEPARTMENT, Triumph Engineering Co. Ltd., Meriden Works, Allesley, Coventry. In order to facilitate quick reference, the quoting of any number, invoice number or reference from previous communications is essential. Accessories not of our manufacture should be sent direct to the actual makers, whose Names and Addresses appear below.

PROPRIETARY GROUP

Ancillary equipment which is fitted to our motor cycles is of the highest quality and is guaranteed by the manufacturers and not by ourselves. Any repairs or claims should be directed to the actual makers or their local agents who will always give owners every possible assistance. The following are the addresses of the various manufacturers:—

CARBURETORS

Messrs. Amal Ltd.,
Holdford Road,
Witton,
Birmingham, 6.

CHAINS.

Renold Chains Ltd.,
Wythenshawe,
Manchester.

ELECTRICAL EQUIPMENT.

Messrs. J. Lucas Ltd.,
Gt. Hampton Street,
Birmingham, 18.

TIRES.

Dunlop Rubber Co. Ltd.,
Fort Dunlop,
Birmingham, 24.

The Avon Rubber Co. Ltd.,
Melksham,
Wilts.

SPARK PLUGS.

Champion Sparking Plug Co. Ltd.,
Feltham,
Middlesex.

INSTRUMENTS.

Messrs. Smiths Industries Ltd.,
Cricklewood Works,
London, N.W.2.

SUSPENSION UNITS.

Messrs. Girling Ltd.,
Birmingham Road,
West Bromwich,
Staffordshire.

OVERSIZE PISTONS AND RINGS

Piston assembly	+ 0.010	71-3686
Compression ring	+ 0.010	71-3691
Scraper ring	+ 0.010	71-3696
Piston assembly	+ 0.020	71-3687
Compression ring	+ 0.020	71-3692
Scraper ring	+ 0.020	71-3697
Piston assembly	+ 0.040	71-3689
Compression ring	+ 0.040	71-3694
Scraper ring	+ 0.040	71-3699

PISTON RING SETS

Ring set—75mm	Std.	99-3788
Ring set—76mm	Std.	99-3789
Ring set—76mm	+ 0.010	99-3790
Ring set—76mm	+ 0.020	99-3791
Ring set—76mm	+ 0.040	99-3792

VALVE GUIDE SETS

Valve guide set	Std.	99-3793
Valve guide set	+ 0.002	99-3794
Valve guide set	+ 0.004	99-3795
Valve guide set	+ 0.006	99-3796

GASKET SETS

Decoke		99-3022
Overhaul		99-3023

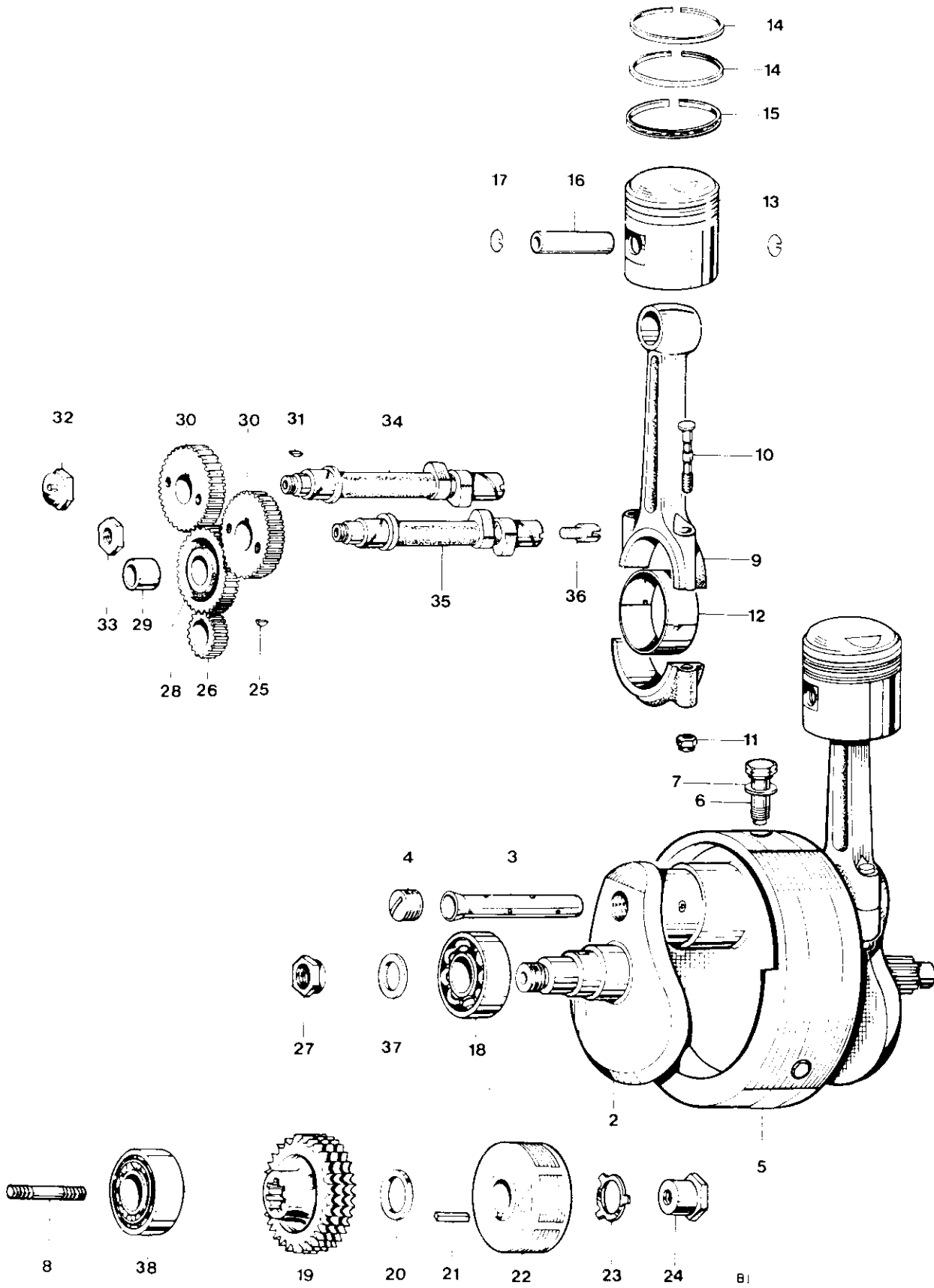

Fig. 1. CRANKSHAFT AND CONNECTING RODS

CRANKSHAFT AND CONNECTING RODS

1	71-3674	CRANKSHAFT AND FLYWHEEL ASSEMBLY	1	
2	71-3298	CRANKSHAFT C/W OIL TUBE	1	
3	70-3903	Oil tube	1	
4	71-2800	Screwed plug	1	
5	71-2425	Flywheel	1	
6	* 71-3552	Flywheel bolt	3	
7	71-1003	Washer	3	
8	21-2183	Crankshaft stud (1 3/8 in. O.A.)	1	
9	71-3006	CONNECTING ROD	2	
10	70-9914	Connecting rod bolt	4	
11	60-3761	Self locking nut	4	
12	70-3586	Big end bearing (Available in — .010in. and .020in. undersizes)	4	
13	71-3476	PISTON COMPLETE	2	
14	71-3690	Taper compression ring	4	
15	71-3695	Oil control ring	2	
16	71-3354	Gudgeon pin	2	
17	71-3700	Circlip	4	
18	60-4167	Main bearing, right	1	
19	71-3542	Motor sprocket, 29 teeth Triplex	1	
20	71-3544	Distance piece	1	
21	71-0082	Rotor key	1	
22	54213901	Rotor (99-0739)	1	
23	70-3975	Tab washer	1	
24	21-2182	Nut	1	
25	70-1580	Key	1	
26	70-4564	Timing pinion	1	
27	71-2877	Nut	1	
28	70-6159	INTERMEDIATE WHEEL	1	
29	70-0400	Intermediate wheel bush	1	
30	71-3666	Camshaft pinion	2	
31	70-1558	Camshaft key	2	
32	71-1007	Inlet camshaft nut	1	
33	70-6523	Exhaust camshaft nut	1	
34	71-3011	Inlet camshaft	1	
35	71-3010	EXHAUST CAMSHAFT	1	
36	70-9988	Tachometer drive plug	1	
37	70-3300	Clamping washer	1	
38	70-2879	Main bearing left	1	
Not illus.	71-2663	Spacer	} Engine sprocket	As required (up to 4)
Not illus.	70-8038	Shim (0.010in.)		
Not illus.	71-2660	Shim (0.030in.)		

*Use 60-0524 Loctite Sealant

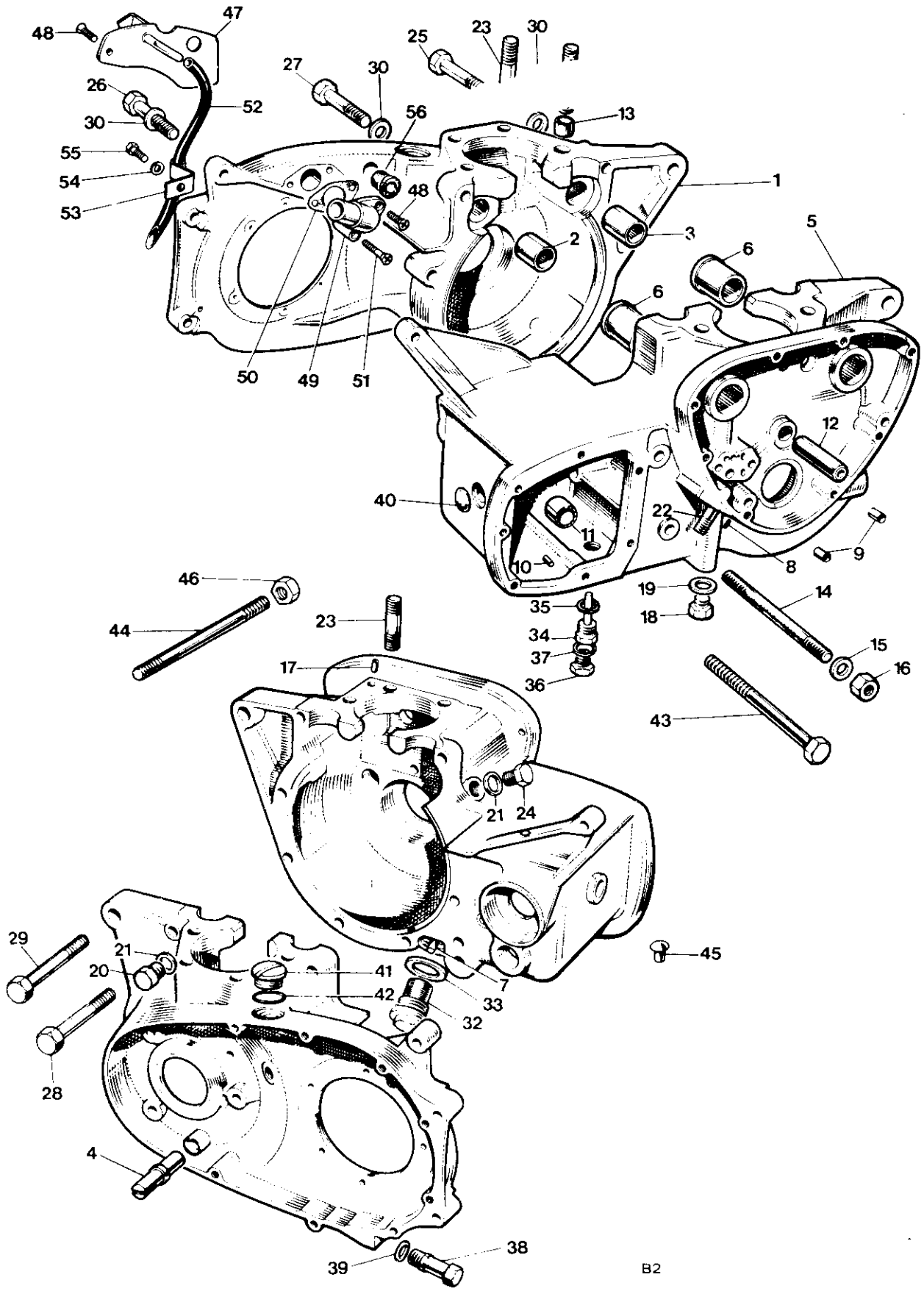

Fig. 2 CRANKCASE

Ref. No.	Part No.	DESCRIPTION	QUANTITY	REMARKS
CRANKCASE				
1	71-3677	CRANKCASE DRIVE SIDE	1	
2	71-0287	Camshaft bush	1	
3	71-0287	Camshaft bush	1	
4	70-5088	Chain tensioner abutment	1	
5	71-3678	CRANKCASE TIMING SIDE	1	
6	71-0286	Camshaft bush	2	
7	70-4538	Scavenge pipe		Reference only
8	70-6386	Locating peg (at oil pipes)		Reference only
9	57-0989	Hollow dowel	2	
10	57-0912	Locating peg (L S at thrust washer)	1	
11	57-1606	Needle roller bearing, layshaft	1	
12	70-0375	Intermediate wheel spindle	1	
13	70-8751	Hollow dowel	1	
14	14-1445	Stud	1	
15	60-4246	Plain washer	2	
16	14-0303	Nut	1	
17	70-1532	Hollow dowel, tappet oil feed	2	
18	70-9330	Oilway plug	1	
19	82-1880	Copper washer	1	
20	21-1871	Tachometer drive plug (L.H. thread)	1	
21	70-8896	Fibre washer	2	
22	21-1863	Oil pipe stud	1	
23	21-1865	Cylinder stud	4	
23	71-3013	Cylinder stud	4	
24	21-1872	Plug, timing hole	1	
25	21-1870	Bolt	1	
26	14-6220	Bolt	1	
27	14-6223	Bolt	1	
28	14-0230	Bolt	1	
29	21-1823	Bolt	2	
30	60-2330	Plain washer	10	
31	14-1302	Nut	5	
32	70-9336	Crankcase filter	1	
33	70-8782	Joint washer	1	
34	57-2167	Drain plug (with level tube)	1	
35	57-1257	Fibre washer	1	
36	21-0543	Level plug	1	
37	70-2441	Copper washer	1	
38	57-2259	Drain and adjuster plug	1	
39	70-6299	"O" ring	1	
40	57-1920	Blanking plug		Reference only
41	57-2166	Filler plug	2	
42	70-8782	"O" ring	2	
43	14-6242	Bolt	1	
44	21-0669	Stud	1	
45	70-7573	Rubber plug	1	
46	14-0402	Nut, exhaust ties	2	
47	71-1072	Breather cover plate assembly	1	
48	71-1075	Screw	1	

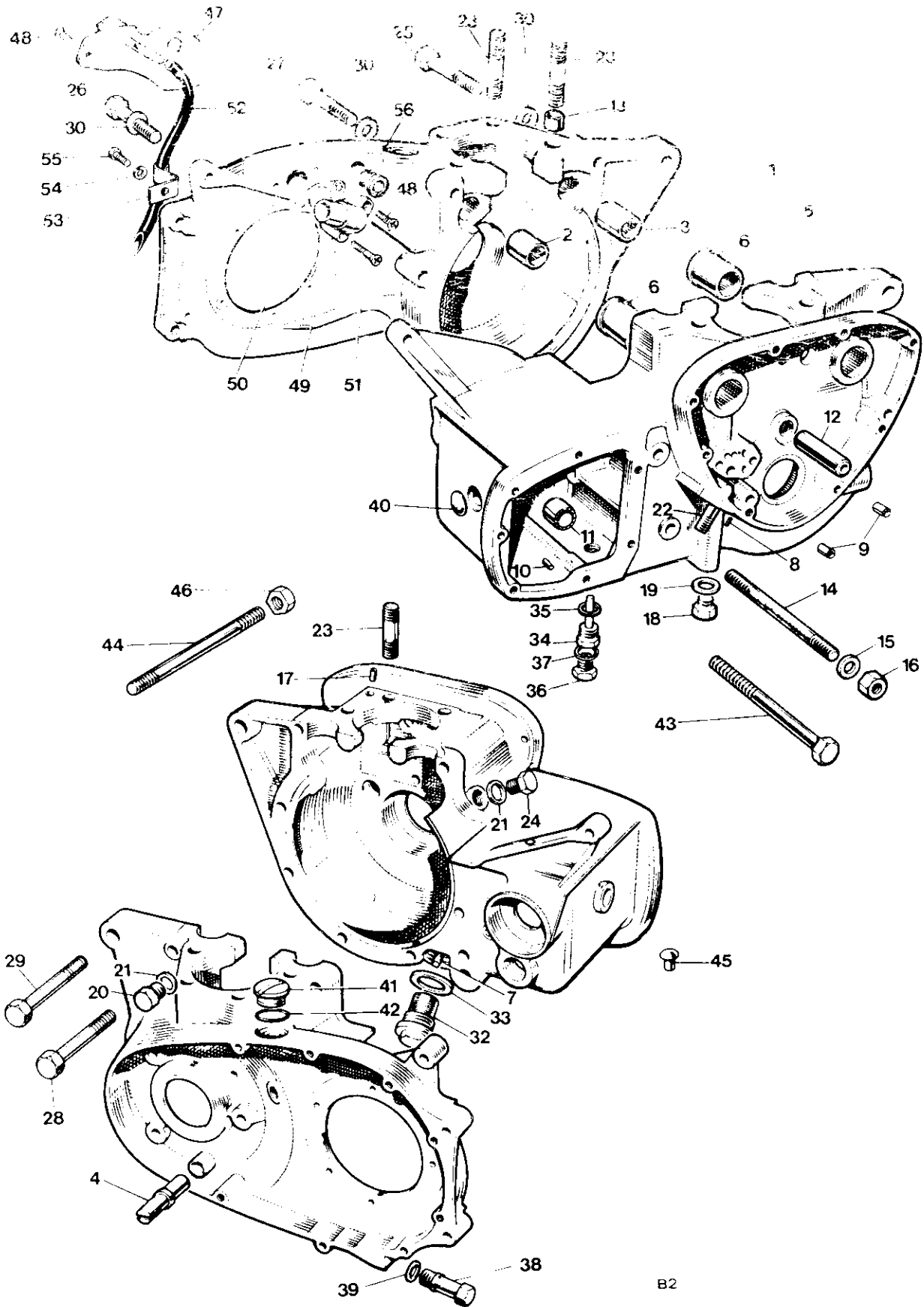

Fig. 2 CRANKCASE

Ref. No.	Part No.	DESCRIPTION	QUANTITY	REMARKS
----------	----------	-------------	----------	---------

CRANKCASE (continued)

49	71-4044	Outlet stub	1	
50	71-1460	Joint washer	1	
51	71-1077	Screw	2	
52	71-3174	Tube, primary chain oiler	1	
53	71-3175	Clip	1	
54	60-4250	Spring washer	1	
55	14-0101	Bolt ($\frac{7}{8}$ in. U.H.)	1	
56	71-1345	Grommet, alternator leads—external	1	

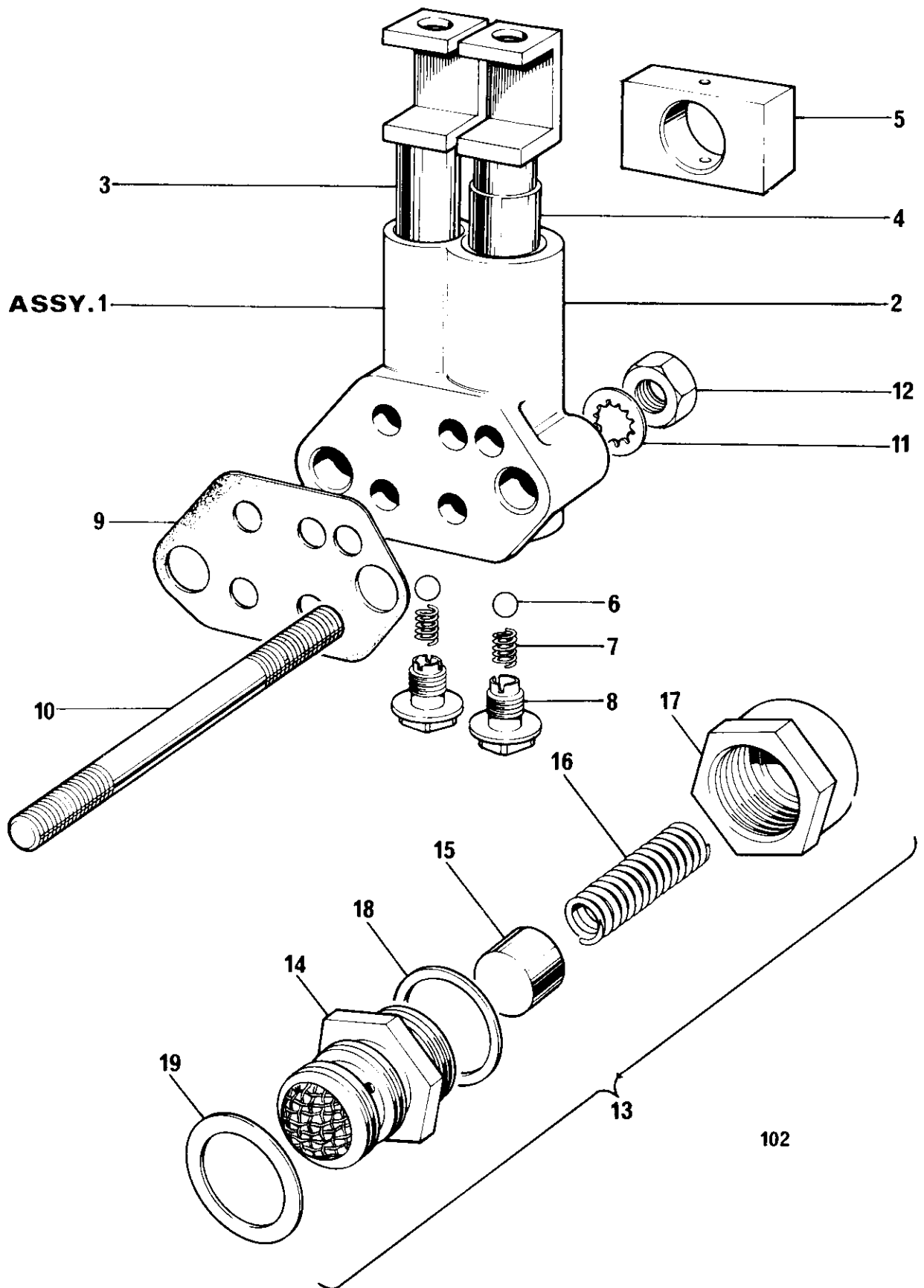

Fig. 3. OIL PUMP AND RELEASE VALVE

OIL PUMP AND RELEASE VALVE

1	70-9421	OIL PUMP	1	
2	Reference only	Pump body...	1	
3	70-9269	Feed plunger	1	
4	70-6681	Scavenger plunger	1	
5	70-0495	Drive block	1	
6	60-2363	Valve ball ($\frac{7}{32}$ in. dia.)	2	
7	70-0403	Valve spring	2	
8	70-2360	Screwed plug	2	
9	71-3910	Joint washer	1	
10	21-1864	Oil pump stud	2	
11	70-3887	Serrated washer	2	
12	21-1906	Nut	2	
13	71-3447	OIL PRESSURE RELEASE VALVE	1	
14	70-7590	Body	1	Reference only
15	70-8752	Piston	1	
16	70-7591	Spring	1	
17	70-6596	Cap ...	1	
18	70-8754	Joint washer (cap to body)	1	
19	70-1670	Joint washer	1	

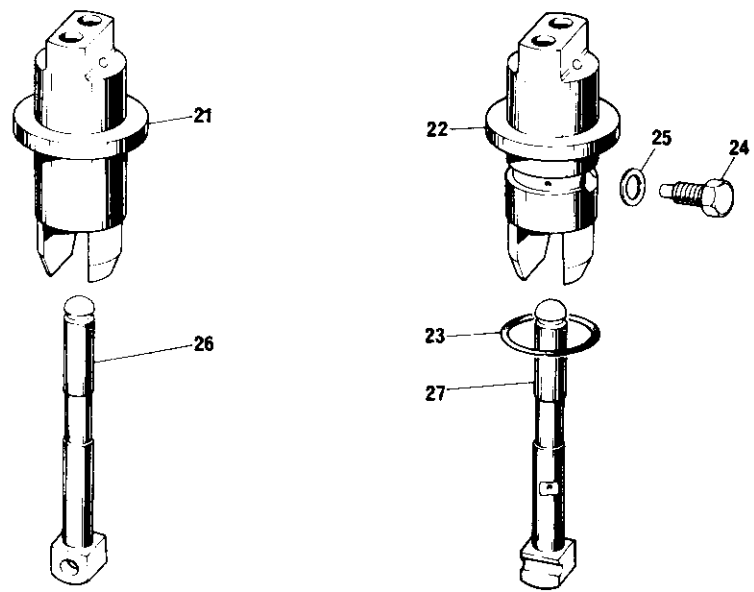
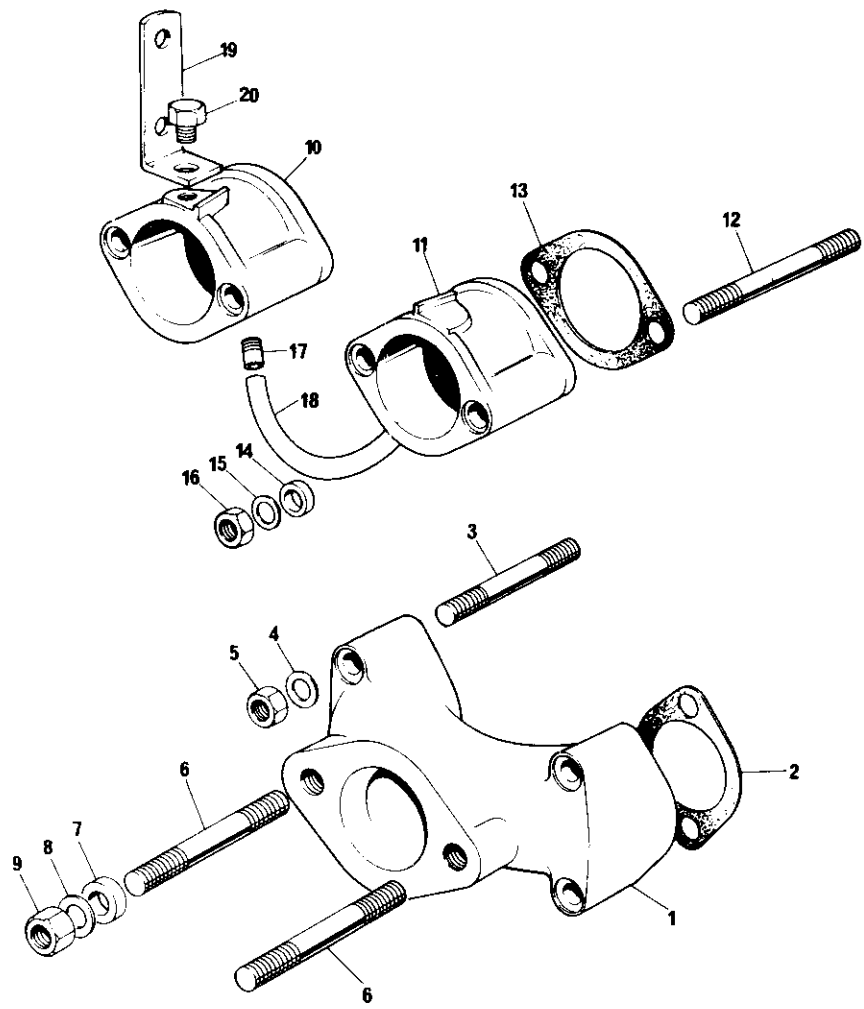

Fig. 4. MANIFOLD AND TAPPETS

MANIFOLD AND TAPPETS

Ref. No.	Part No.	Description	Quantity	Remarks
1	71-3556	Inlet manifold	1	TR7RV
2	70-5660	Joint washer	2	
3	21-1876	Stud	4	
4	60-4248	Washer	4	
5	21-1877	Nut	4	
6	21-1996	Stud	2	
7	70-9554	Insulating ring	2	
8	70-9555	Cup	2	
9	14-1301	Nut	2	
10	71-3339	Inlet manifold—L.H.	1	
11	71-3338	Inlet manifold—R.H.	1	
12	71-2813	Stud	4	
13	71-3573	Joint washer	2	
14	70-9554	Insulating ring	4	
15	70-9555	Cup	4	
16	14-1301	Nut	4	
17	71-3313	Connector	2	
18	71-3577	Connector pipe	1	
19	83-4898	Bracket—Air control lever	1	
20	21-1903	Screw	1	
21	70-9352	Inlet tappet guide block	1	
22	70-9353	Exhaust tappet guide block	1	
23	70-7563	'O' ring	2	
24	97-0200	Set bolt	2	
25	70-2441	Washer	2	
26	70-3059	Inlet tappet	2	
27	70-8801	Exhaust tappet	2	

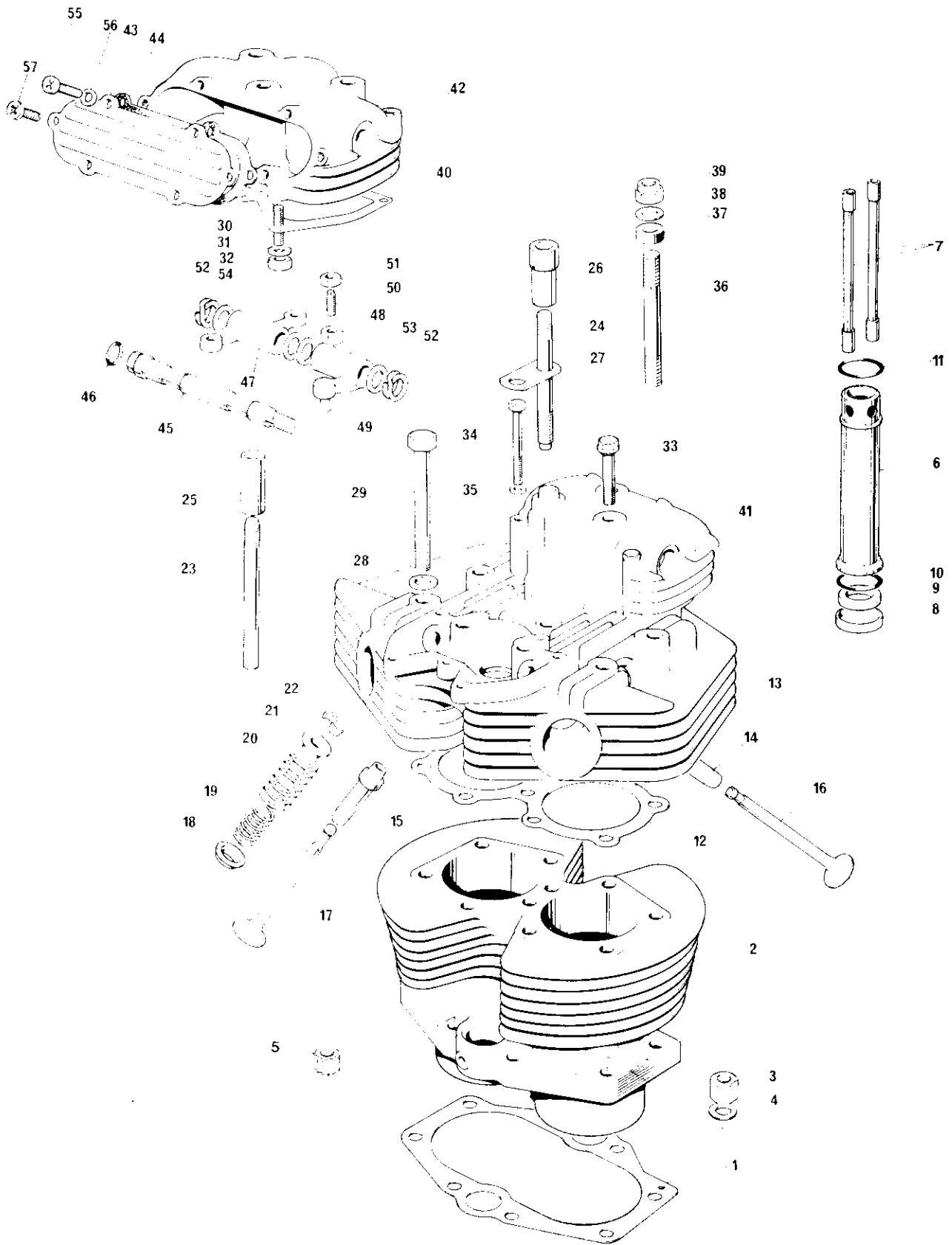

Fig. 5. CYLINDER BLOCK AND HEAD, TR7RV

CYLINDER BLOCK AND HEAD TR7RV

1	70-6309	Cylinder base washer ...	1	
2	71-4005	Cylinder block ...	1	
3	21-2177	Cylinder base nut ...	4	
4	70-3446	Washer ...	4	
5	21-0692	Cylinder base nut (12 point)	4	
6	71-3329	Push rod cover tube ...	2	
7	71-3330	Push rod ...	4	
8	71-1707	Sleeve ...	2	} Cover tubes
9	70-4752	Sealing ring ...	2	
10	70-7310	'O' ring—bottom ...	2	
11	71-1283	'O' ring—top ...	2	
12	71-3681	Cylinder head gasket ...	1	
13	71-3558	CYLINDER HEAD ...	1	
14	71-3294	Inlet valve guide ...	2	
15	71-3295	Exhaust valve guide ...	2	
16	70-4603	Inlet valve ...	2	
17	70-2904	Exhaust valve ...	2	
18	71-3296	Bottom cup ...	4	
19	70-4221	Inner valve spring ...	4	
20	70-7400	Outer valve spring ...	4	
21	70-1543	Top collar ...	4	
22	99-0062	Split cotter ...	8	
23	21-2201	Stud—cylinder head ($\frac{3}{8}$ in.) ...	4	
24	21-2200	Stud—cylinder head ($\frac{5}{16}$ in.) ...	2	
25	21-2204	Socket nut ($\frac{3}{8}$ in.) ...	4	
26	21-2205	Socket nut ($\frac{5}{16}$ in.) ...	2	
27	71-3553	Bridge plate ...	1	
28	82-2184	Washer ...	8	
29	14-0241	Bolt—cylinder head ...	4	
30	14-1401	Stud—rocker box ...	6	
31	70-3302	Washer ...	6	
32	14-0301	Nut ...	6	
33	21-2206	Bolt—rocker box ...	4	
34	21-1875	Bolt—rocker box ...	4	
35	60-4248	Washer ...	4	
36	21-2197	Stud ...	2	} Torque stay
37	37-2338	Distance piece ...	2	
38	60-2331	Washer ...	2	
39	14-1303	Nut ...	2	
40	71-2599	Rocker box gasket ...	2	
41	71-3668	Inlet rocker box ...	1	
42	71-3669	Exhaust rocker box ...	1	
43	71-3671	Tappet inspection cover ...	2	
44	71-3673	Gasket ...	2	
45	71-3549	Rocker spindle ...	2	
46	60-3548	Sealing ring ...	2	

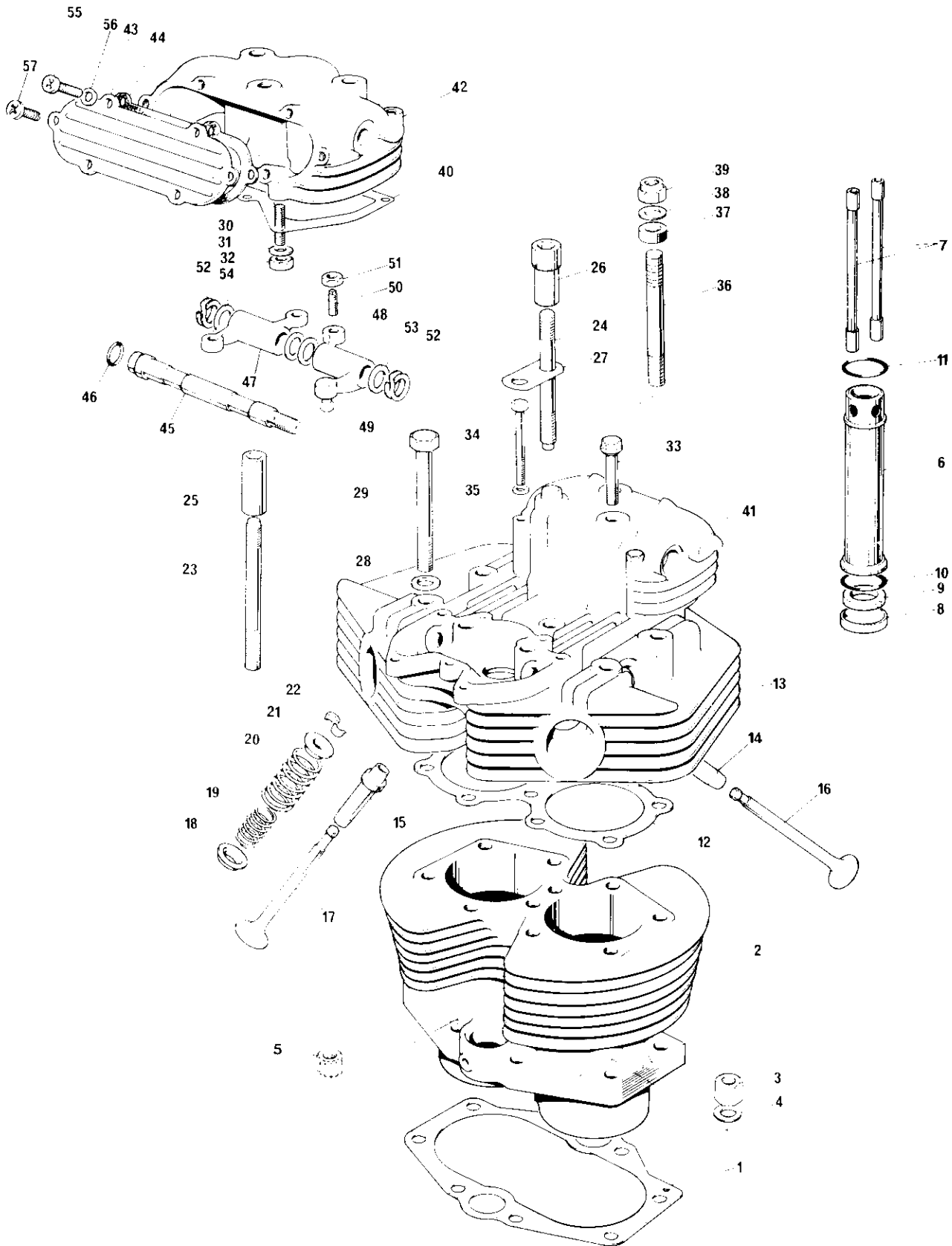

Fig. 6. CYLINDER BLOCK AND HEAD, TR7RV

CYLINDER BLOCK AND HEAD, TR7RV (continued)

47	70-1457	Rocker (right exhaust, left inlet)	2	
48	70-1458	Rocker (left exhaust, right inlet)	2	
49	71-0070	Ball pin	4	
50	70-1513	Adjusting pin	4	
51	70-0470	Lock nut	4	
52	70-1574	Spring washer	4	
53	70-1575	Thrust washer ($\frac{1}{2}$ in.)	6	
54	70-1330	Thrust washer ($\frac{3}{8}$ in.)	2	
55	14-6103	Set screw	4	
56	60-3963	Washer	12	
57	14-6606	Set screw	8	

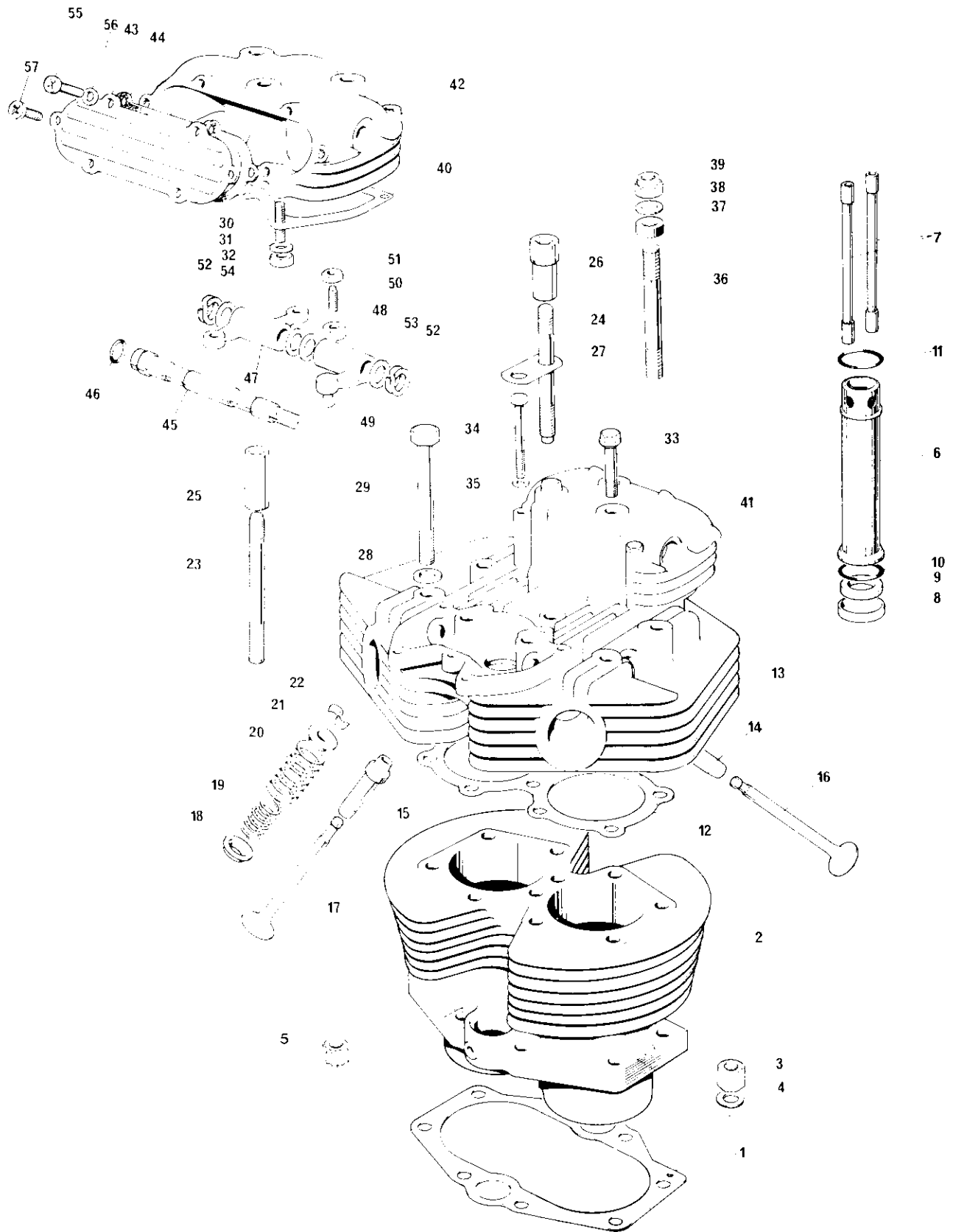

Fig. 7. CYLINDER BLOCK AND HEAD, TI40V

CYLINDER BLOCK AND HEAD, T140V

1	70-6309	Cylinder base washer ...	1	
2	71-4005	Cylinder block ...	1	
3	21-2177	Cylinder base nut ...	4	
4	70-3446	Washer ...	4	
5	21-0692	Cylinder base nut (12 point)	4	
6	71-3329	Push rod cover tube ...	2	
7	71-3330	Push rod ...	4	
8	71-1707	Sleeve ...	2	
9	70-4752	Sealing ring ...	2	} Cover tubes
10	70-7310	'O' ring—bottom ...	2	
11	71-1283	'O' ring—top ...	2	
12	71-3681	Cylinder head gasket ...	1	
13	71-3023	CYLINDER HEAD ...	1	
14	71-3294	Inlet valve guide ...	2	
15	71-3295	Exhaust valve guide ...	2	
16	70-4603	Inlet valve ...	2	
17	70-2904	Exhaust valve ...	2	
18	71-3296	Bottom cup ...	4	
19	70-4221	Inner valve spring ...	4	
20	70-7400	Outer valve spring ...	4	
21	70-1543	Top collar ...	4	
22	99-0062	Split cotter ...	8	
23	21-2201	Stud—cylinder head ($\frac{3}{8}$ in.) ...	4	
24	21-2200	Stud—cylinder head ($\frac{5}{16}$ in.) ...	2	
25	21-2204	Socket nut ($\frac{3}{8}$ in.) ...	4	
26	21-2205	Socket nut ($\frac{5}{16}$ in.) ...	2	
27	71-3553	Bridge plate ...	1	
28	82-2184	Washer ...	8	
29	14-0241	Bolt—cylinder head ...	4	
30	14-1401	Stud—rocker box ...	6	
31	70-3302	Washer ...	6	
32	14-0301	Nut ...	6	
33	21-2206	Bolt—rocker box ...	4	
34	21-1875	Bolt—rocker box ...	4	
35	60-4248	Washer ...	4	
36	21-2197	Stud ...	2	} Torque stay
37	37-2338	Distance piece ...	2	
38	60-2331	Washer ...	2	
39	14-1303	Nut ...	2	
40	71-2599	Rocker box gasket ...	2	
41	71-3668	Inlet rocker box ...	1	
42	71-3669	Exhaust rocker box ...	1	
43	71-3671	Tappet inspection cover ...	2	
44	71-3673	Gasket ...	2	
45	71-3549	Rocker spindle ...	2	
46	60-3548	Sealing ring ...	2	

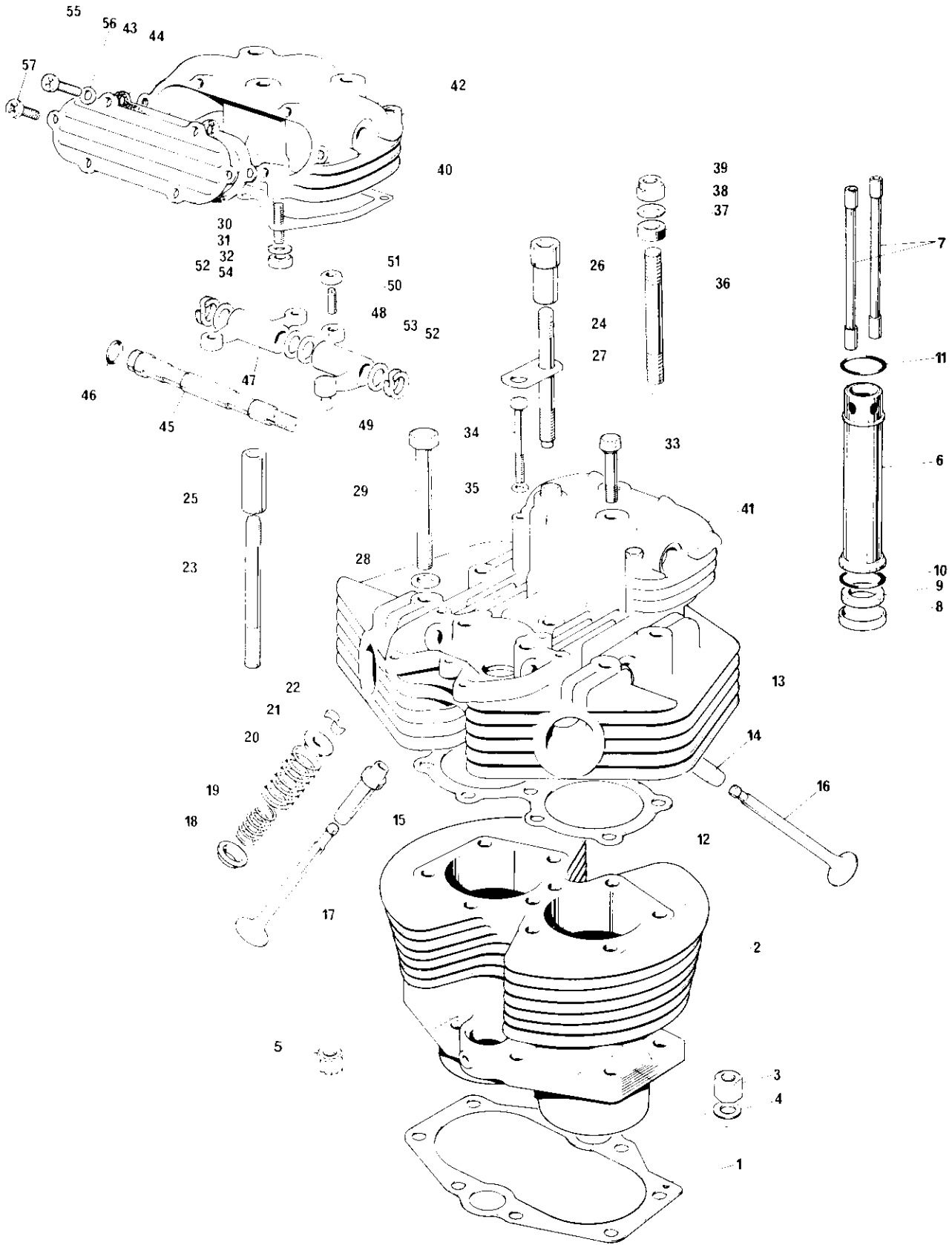
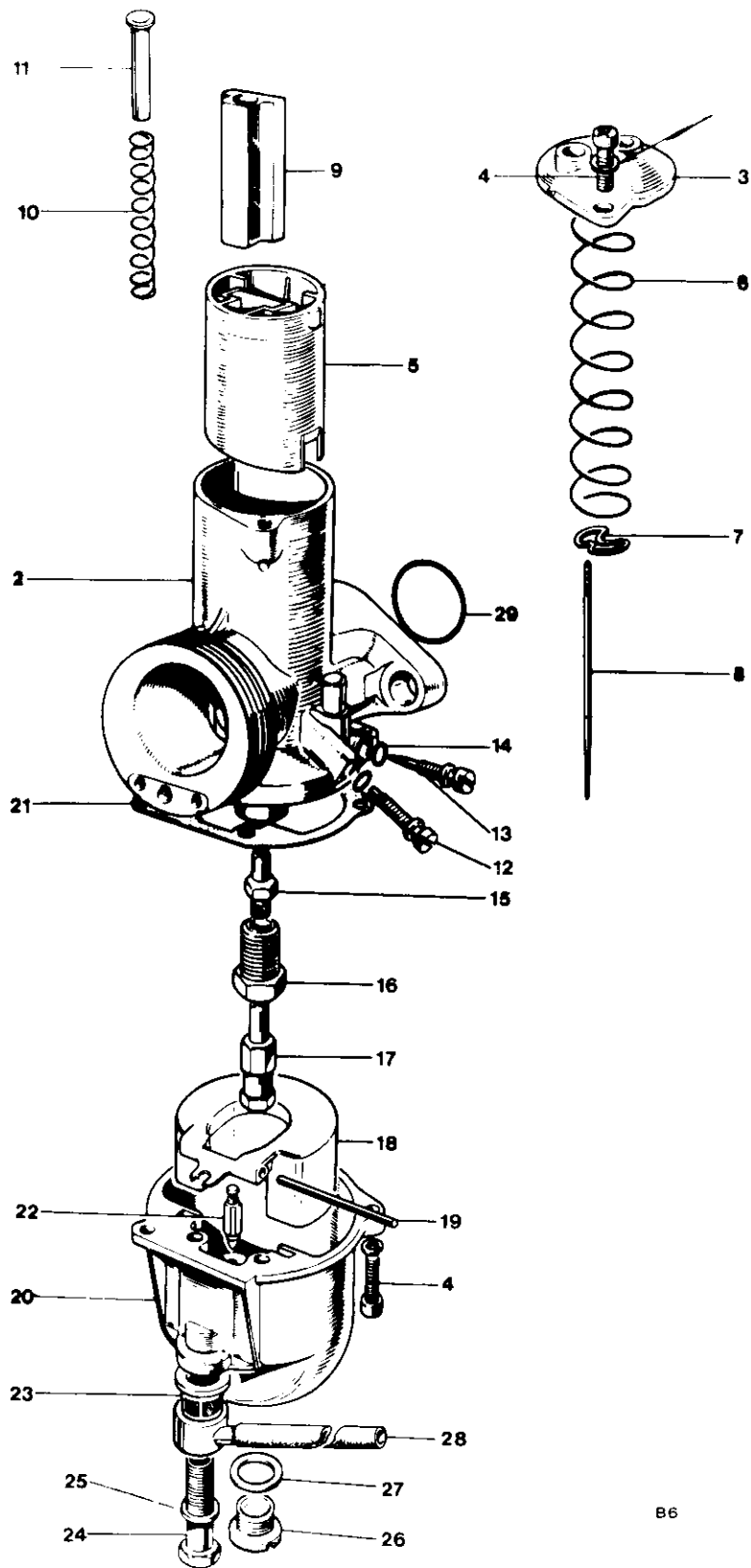

Fig. 7. CYLINDER BLOCK AND HEAD, TI40V

CYLINDER BLOCK AND HEAD, T140V (continued)

47	70-1457	Rocker (right exhaust, left inlet)	2	
48	70-1458	Rocker (left exhaust, right inlet)	2	
49	71-0070	Ball pin	4	
50	70-1513	Adjusting pin	4	
51	70-0470	Lock nut	4	
52	70-1574	Spring washer	4	
53	70-1575	Thrust washer ($\frac{1}{2}$ in.)	6	
54	70-1330	Thrust washer ($\frac{3}{8}$ in.)	2	
55	14-6103	Set screw	4	
56	60-3963	Washer	12	
57	14-6606	Set screw	8	



B6

Fig. 8. AMAL CARBURETOR, TR7RV

CARBURETOR TR7RV

1	60-2183	CARBURETOR (R930/89) less "O" ring	1	
2	Reference only	Mixing chamber (930/005)	1	
3	928/098	Mixing chamber top (99-1032)	1	
4	622/086	Screw (99-0521)	4	
5	928/060	Throttle valve (3½ cutaway) (99-0527)	1	
6	622/131	Throttle return spring (99-1033)	1	
7	622/067	Needle clip (99-0510)	1	
8	622/124	Needle (99-1036)	1	
9	928/062	Air slide (99-0528)	1	
10	622/129	Spring (99-1038)	1	
11	928/103	Air valve guide sleeve (99-1037)	1	
12	622/077	Throttle stop screw (99-0516)	1	
13	622/076	Air adjusting screw (99-0515)	1	
14	622/082	"O" ring (99-0520)	2	
15	622/122	Needle jet (0-106) (99-1035)	1	
16	622/128	Jet holder (99-1034)	1	
17	376/100	Main jet (280) (99-0455)	1	
18	622/069	Float (99-0512)	1	
19	622/071	Float spindle (99-0513)	1	
20	622/055	Float chamber (99-0506)	1	
21	622/073	Joint washer (99-0514)	1	
22	622/068	Needle (99-0511)	1	
23	376/093	Filter (99-0438)	1	
24	622/078	Banjo bolt (99-0517)	1	
25	13/163	Fibre washer (99-1124)	1	
26	622/147	Drain plug (99-1152)	1	
27	622/151	Washer (99-1153)	1	
28	83-4887	Petrol pipe	1	
29	70-9711	"O" ring	1	

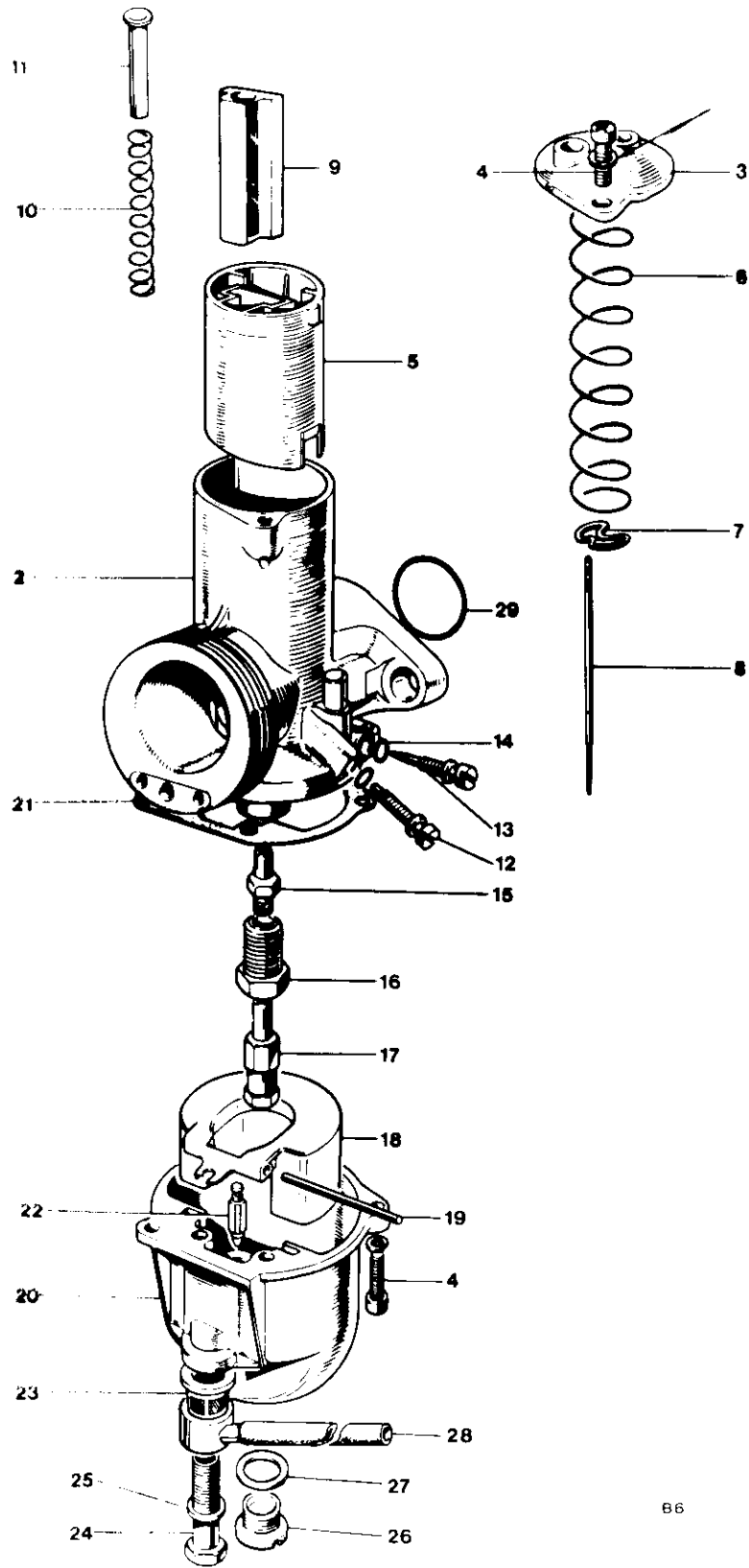

86

Fig. 9. AMAL CARBURETOR, TI40V

CARBURETOR T140V

1	60-4305	CARBURETOR—L.H. (R930:93)	1	} Less "O" ring
1	60-4306	CARBURETOR—R.H. (R930:92)	1	
2	Reference only	Mixing chamber (L930/005 and R930/005)	1	} Each carburetor
3	928/098	Mixing chamber top (99-1032)	1	
4	622/086	Screw (99-0521)	4	
5	928/060	Throttle valve (3 cutaway) (99-0527)	1	
6	622/131	Throttle return spring (99-1033)	1	
7	622/067	Needle clip (99-0510)	1	
8	622/124	Needle (99-1036)	1	
9	928/062	Air slide (99-0528)	1	
10	622/129	Spring (99-1038)	1	
11	928/103	Air valve guide sleeve (99-1037)	1	
12	622/077	Throttle stop screw (99-0516)	1	
13	622/076	Air adjusting screw (99-0515)	1	
14	622/082	"O" ring (99-0520)	2	
15	622/122	Needle jet (0-106) (99-1035)	1	
16	622/128	Jet holder (99-1034)	1	
17	376/100	Main jet (210) (99-0448)	1	
18	622/069	Float (99-0512)	1	
19	622/071	Float spindle (99-0513)	1	
20	622/055	Float chamber (99-0506)	1	
21	622/073	Joint washer (99-0514)	1	
22	622/068	Needle (99-0511)	1	
23	376/093	Filter (99-0438)	1	
24	622/078	Banjo bolt (99-0517)	1	
25	13/163	Fibre washer (99-1124)	1	
26	622/147	Drain plug (99-1152)	1	
27	622/151	Washer (99-1153)	1	
28	83-3927	Petrol pipe	1	
29	70-9711	"O" ring	2	

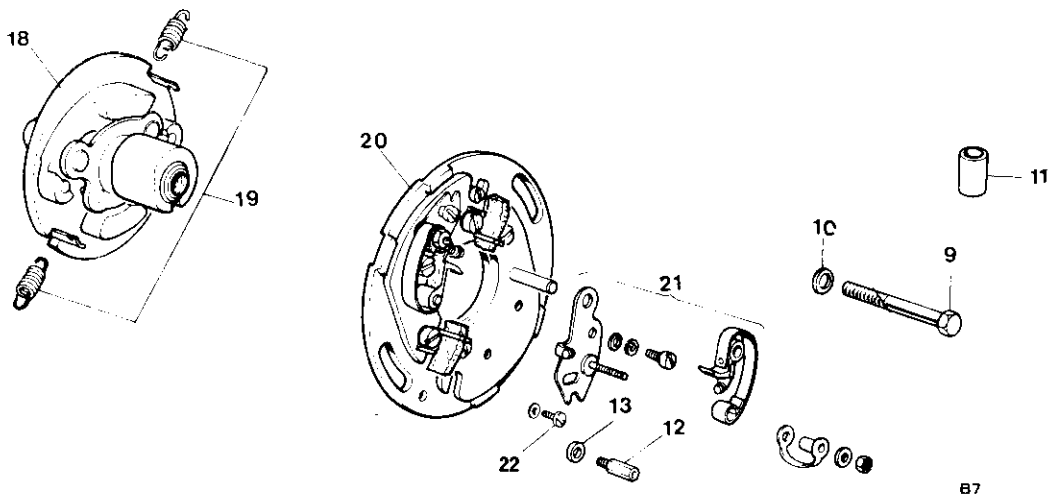
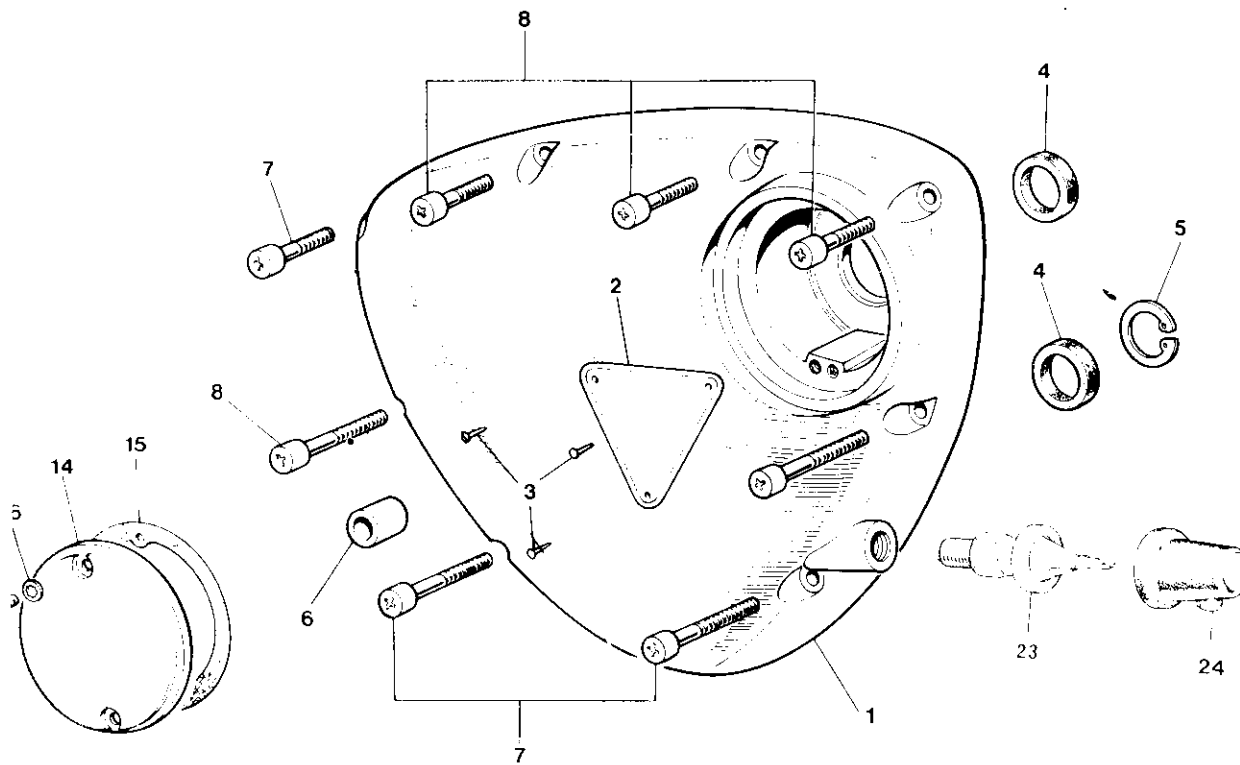
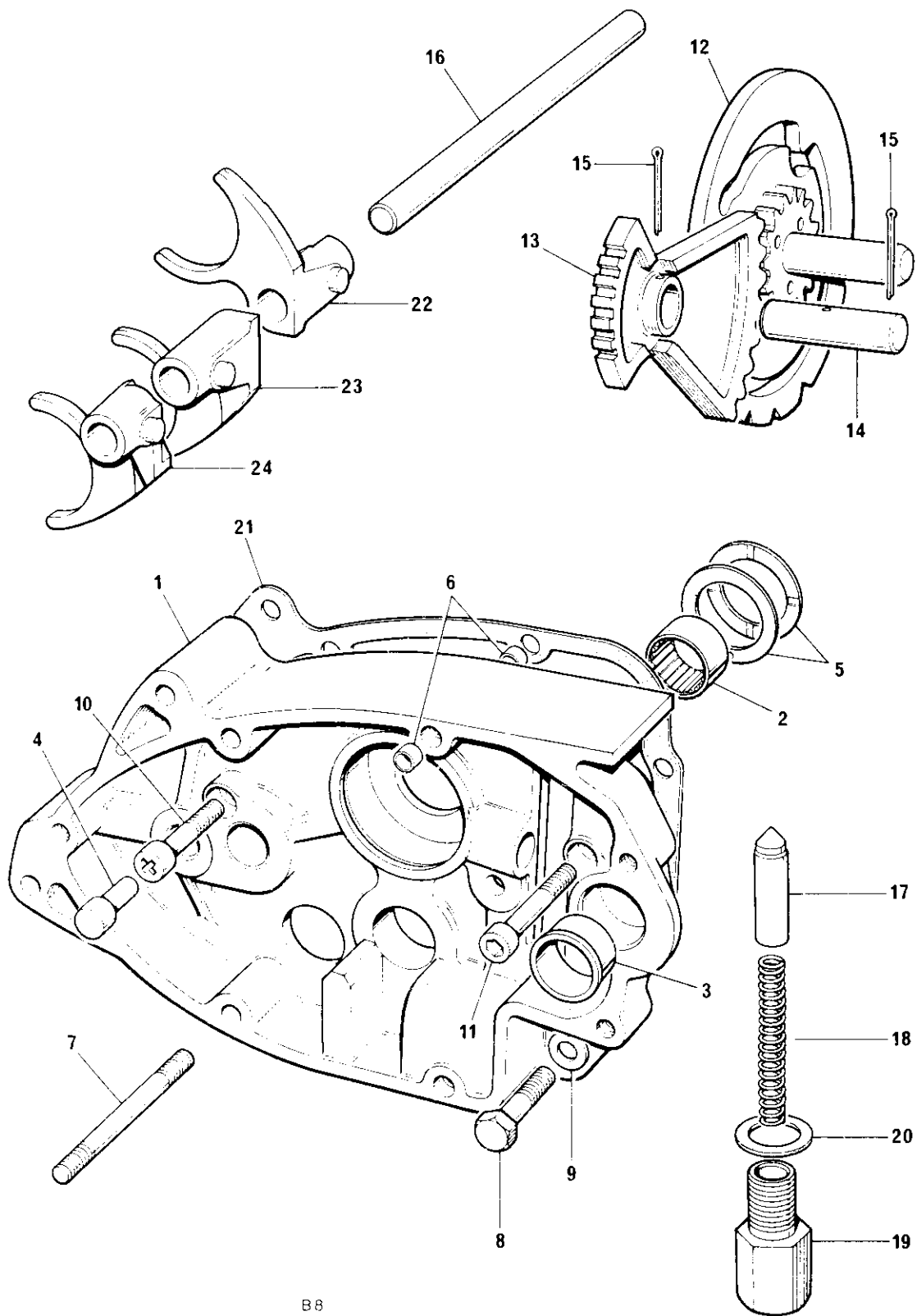

Fig. 10. TIMING COVER AND CONTACT BREAKER

TIMING COVER AND CONTACT BREAKER

1	70-9246	Timing cover	1	
2	70-4016	Patent plate	1	
3	60-4255	Hammer-drive screw	3	
4	70-4568	Oil seal	2	
4	70-6387	Oil seal (0.020 in. undersize)		For reground crankshaft
5	70-4569	Circlip	1	
6	57-0989	Hollow dowel	1	
7	14-6609	Screw	3	
8	14-6608	Screw	5	
9	14-0208	Bolt	1	
10	70-8163	Plain washer	1	
11	70-4707	Rubber grommet	1	
12	70-7680	Pillar bolt	2	
13	70-6559	Plain washer	2	
14	70-8737	Cover	1	
15	71-1462	Joint washer	1	
16	60-4256	Serrated washer	2	
17	70-7354	Screw ($\frac{1}{2}$ in. U.H.)	2	
18	54425657	AUTO ADVANCE UNIT (99-1263)	1	
19	54412229	Spring set (99-1264)	1	
20	54425160	CONTACT BREAKER PLATE ASSEMBLY (99-1265)	1	
21	60600271	Contact set (99-1266)	2	
22	54419220	Pin, adjustment (99-0769)	2	
23	60-3719	Oil pressure switch	1	
24	71-2930	Cover pressure switch	1	
Not illus.	60-2138	Timing label for C.B. cover	1	



B8

Fig. II GEARBOX INNER COVER AND SELECTORS

Ref. No.	Part No.	DESCRIPTION	QUANTITY	REMARKS
----------	----------	-------------	----------	---------

GEARBOX INNER COVER AND SELECTORS

1	57-4795	GEARBOX INNER COVER	1	
2	57-1614	Layshaft bearing	1	
3	57-0412	Gearchange spindle bush... ..	1	
4	57-0045	Kickstart stop	1	
5	57-1607	Thrust washer	2	
6	57-0989	Hollow dowel	4	
7	21-2149	Stud	2	
8	21-1907	Bolt	1	
9	70-3446	Washer	1	
10	14-6608	Screw	1	
11	14-7023	Screw	1	
12	57-4624	Camplate	1	
13	57-4363	Operating quadrant	1	
14	57-1896	Quadrant spindle	1	
15	—	Split pin ($\frac{5}{64}$ in. x $1\frac{3}{8}$ in.)	1	Reference only
16	57-3989	Selector fork rod	1	
17	57-3660	Index plunger	1	
18	57-4459	Plunger spring	1	
19	57-4400	Housing, index plunger	1	
20	57-3978	Washer	1	
21	71-3096	Joint washer, inner cover to crankcase	1	
22	57-4364	Selector fork - mainshaft 4th gear	1	
23	57-4366	Selector fork - layshaft 3rd gear	1	
24	57-4660	Selector fork - layshaft 1st gear	1	

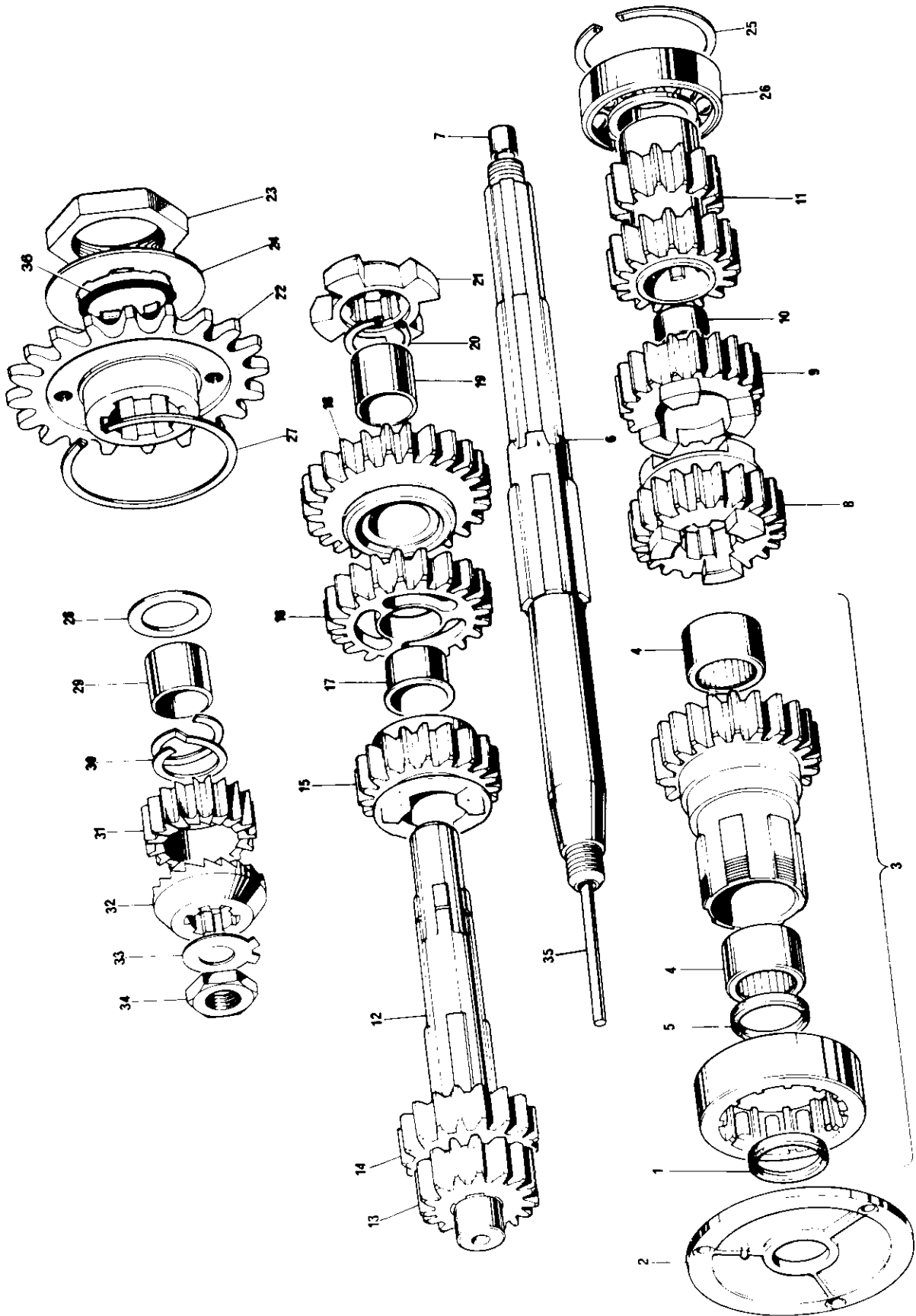

FIG. 12 GEARBOX SHAFTS AND GEARS (5 SPEED)

GEARBOX SHAFTS AND GEARS

1	60-3500	Oil seal, cover plate	1	
2	70-3789	Cover plate	1	
3	57-4781	MAINSHAFT HIGH GEAR ASSEMBLY (C/W HIGH GEAR BEARING)	1	
4	60-3511	Needle roller bearing	2	
5	60-3500	Oil seal, high gear	1	
6	57-4432	MAINSHAFT	1	
7	57-3988	Bush	1	
8	57-4376	Mainshaft 4th gear	1	
9	57-4377	MAINSHAFT 3rd GEAR	1	
10	57-4575	Bush		Reference only
11	57-4653	Mainshaft 1st and 2nd gear	1	
12	57-4900	LAYSHAFT	1	
13	57-4550	Layshaft high gear		Reference only
14	57-4384	Layshaft 4th gear		Reference only
15	57-4647	Layshaft 3rd gear	1	
16	57-4657	LAYSHAFT 2nd GEAR	1	
17	57-4662	Bush	1	
18	57-4654	LAYSHAFT 1st GEAR	1	
19	57-4663	Bush	1	
20	60-3494	Circlip	1	
21	57-4661	Driving dog	1	
22	57-4782	Gearbox sprocket - 20T	1	
23	57-4396	Locknut	1	
24	57-4909	Lock washer	1	
Not illus.	60-3512	Oil seal, gearbox	1	
25	70-0489	Circlip	1	
26	60-3552	Mainshaft bearing	1	
27	57-4113	Circlip	1	
28	57-1962	Washer	1	
29	57-1963	Pinion sleeve	1	
30	57-1250	Pinion spring	1	
31	57-0730	Kickstart pinion	1	
32	57-0731	Kickstart ratchet	1	
33	57-2240	Tab washer	1	
34	21-0594	Nut	1	
35	57-1736	Clutch operating rod	1	
36	71-1070	"O" ring, gea. box sprocket	1	

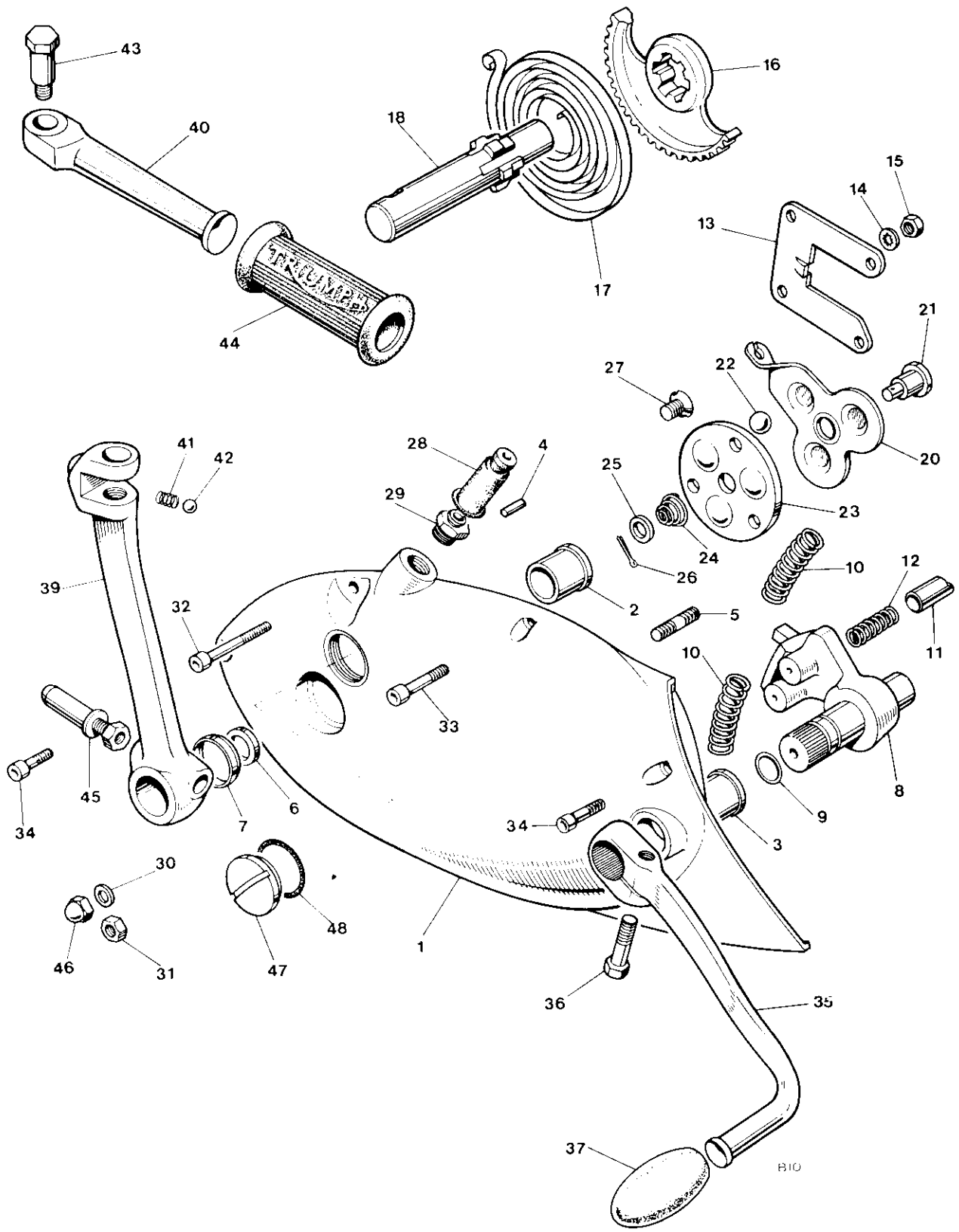

Fig. 13. GEARBOX OUTER COVER

Ref. No.	Part No.	DESCRIPTION	QUANTITY	REMARKS
GEARBOX OUTER COVER				
1	57-3760	GEARBOX OUTER COVER	1	
2	57-0023	Kickstarter spindle bush	1	
3	57-0057	Gearchange spindle bush	1	
4	57-0047	Kickstarter spring anchor pin	1	
5	21-0547	Guide plate stud	4	
6	57-1956	Oil seal	1	
7	57-1955	Oil seal housing	1	
8	57-4910	Gearchange quadrant	1	
9	60-3530	Rubber "O" ring	1	
10	57-0404	Quadrant return spring	2	
11	57-0406	Gearchange quadrant plunger	2	
12	57-0405	Plunger spring	2	
13	57-0407	Guide plate	1	
14	70-1612	Serrated washer	4	
15	14-0301	Nut	4	
16	57-4117	Kickstarter quadrant	1	
17	57-0031	Kickstarter return spring	1	
18	57-0024	Kickstarter axle	1	
19	57-4587	CLUTCH LEVER ASSEMBLY	1	
20	57-4588	Clutch lever	1	
21	57-1710	Lever shaft	1	
22	60-2368	Ball, $\frac{3}{8}$ in. diam.	3	
23	57-4589	Thrust plate	1	
24	57-1712	Return spring	1	
25	57-3673	Plain washer	1	
26	—	Split pin ($\frac{5}{64}$ in. x $\frac{1}{2}$ in.)		Reference only
27	21-1879	Countersunk screw	2	
28	57-1646	Rubber cover	1	
29	57-3762	Abutment for clutch cable	1	
30	60-4247	Plain washer	2	
31	14-0302	Nut	1	
32	21-2162	Screw	2	
33	14-6609	Screw	2	
34	14-6608	Screw	1	
35	57-3757	Gearchange pedal	1	
36	14-0200	Bolt	1	
37	57-2450	Pedal rubber	1	
38	57-3630	FOLDING KICKSTARTER	1	
39	57-2173	Kickstarter lever	1	
40	57-1270	Kickstarter pedal	1	
41	57-1167	Pedal locating spring	1	
42	60-2364	Steel ball, $\frac{1}{4}$ in. diam.	2	
43	21-0543	Pedal bolt	1	
44	57-2330	Pedal rubber	1	
45	57-4352	Cotter pin c/w nut and washer	1	
46	21-0544	Domed nut	1	
47	57-2168	Filler plug	1	
48	70-8782	"O" ring	1	

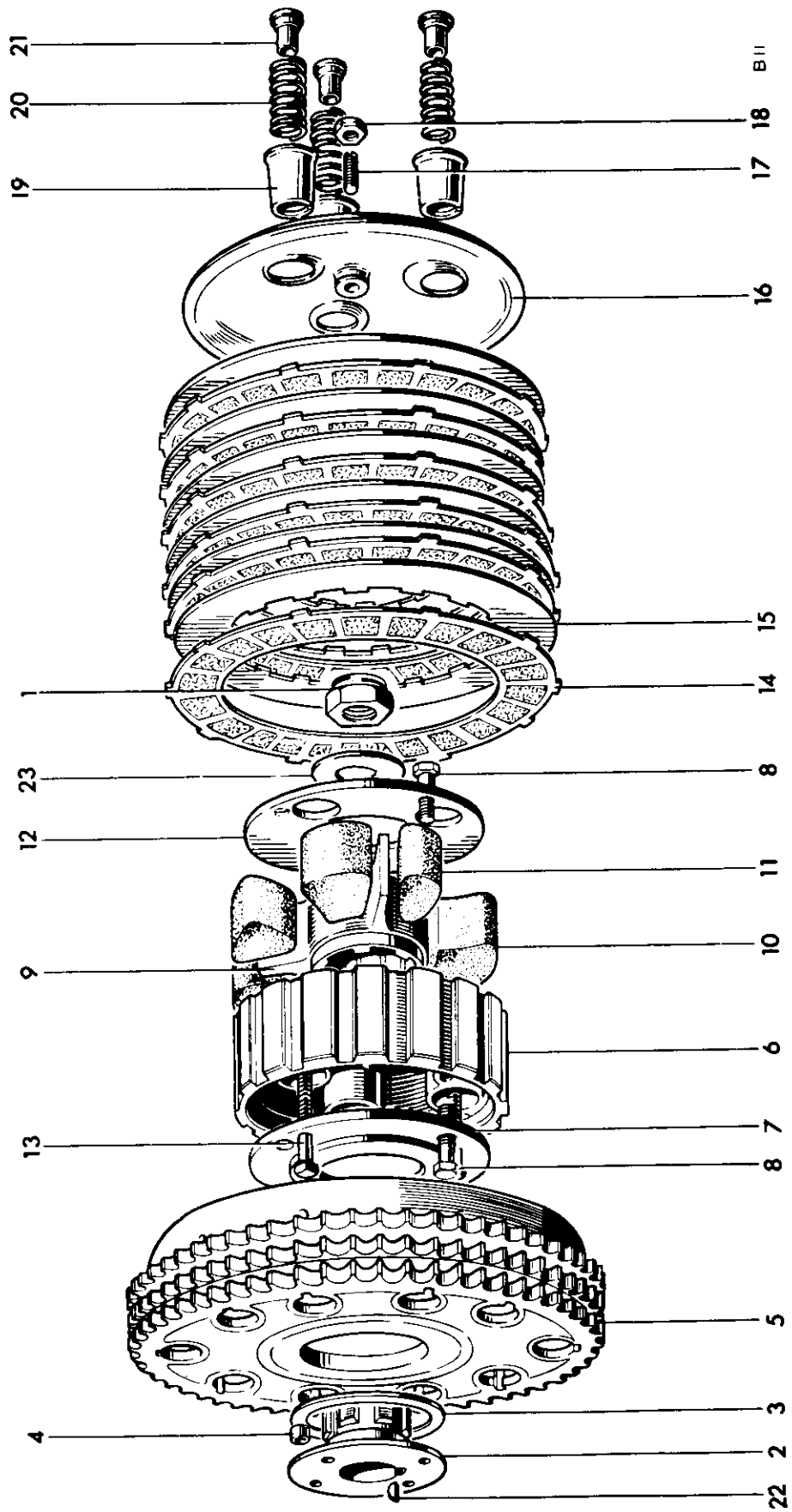
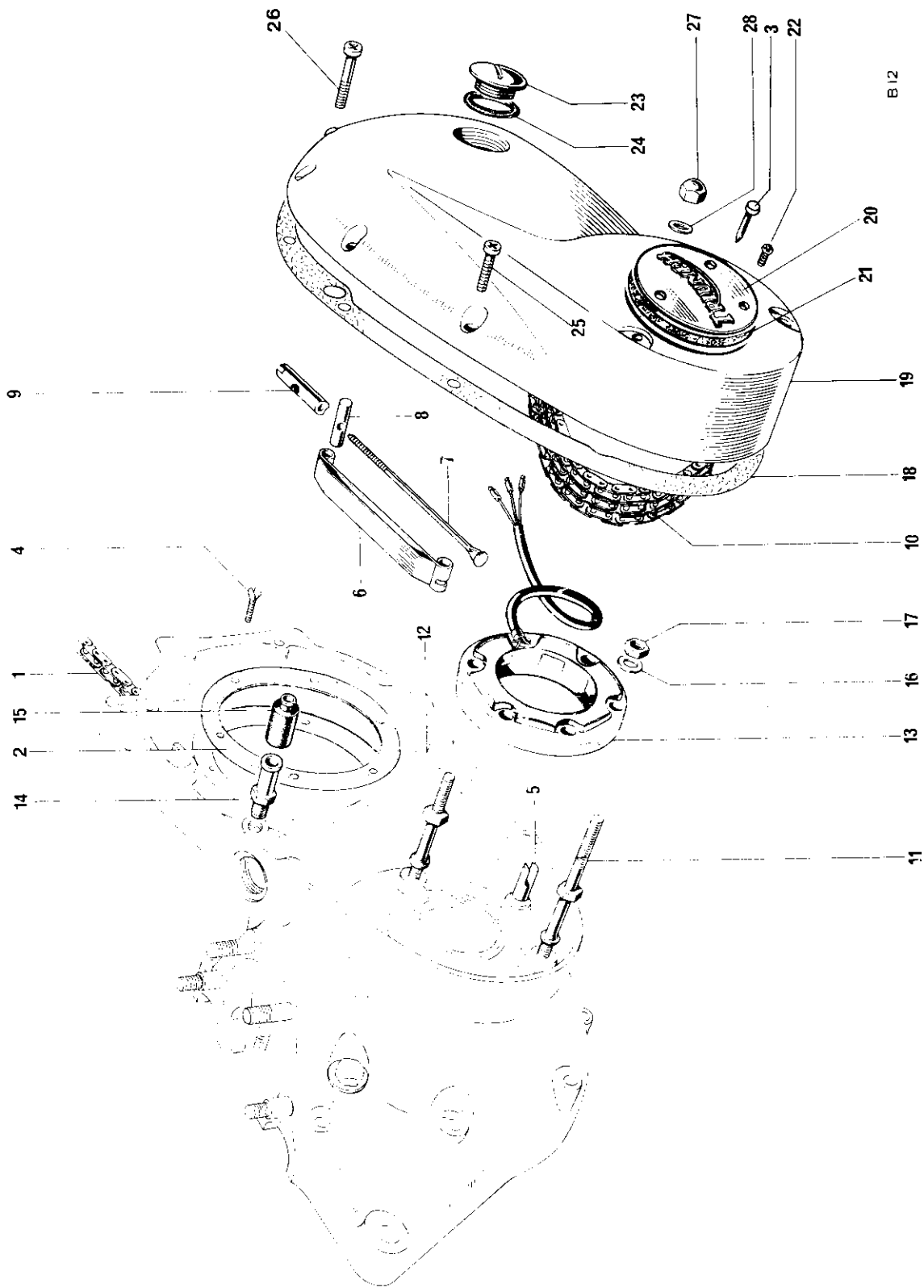

Fig. 14. CLUTCH

CLUTCH

1	21-0586	Clutch securing nut	1	
2	57-3929	Hub	1	
3	57-3931	Thrust washer	1	
4	57-0394	Roller	20	
5	57-4640	Sprocket and housing	1	
6	57-4438	Centre	1	
7	57-4436	Inner plate	1	
8	21-2157	Bolt	3	
9	57-4636	Shock absorber spider	1	
10	57-1722	Drive rubber (large)	3	
11	57-1723	Rebound rubber (small)	3	
12	57-4437	Outer plate	1	
13	57-4754	Screwed pin	3	
14	57-1362	Driving plate (bonded)	6	
15	57-1363	Driven plate	6	
16	57-4590	Pressure plate	1	
17	57-2159	Adjuster pin	1	
18	14-0403	Nut	1	
19	57-1931	Spring cup	3	
20	57-4644	Spring	3	
21	57-2526	Pressure nut	3	
22	60-4253	Key	1	
23	57-4794	Washer	1	



B 12

FIG. 15. CHAINCASE AND CHAINS

CHAINCASE AND CHAINS

1	60-2118	Rear chain, $\frac{5}{8}$ in. x $\frac{3}{8}$ in. x 107 links	1	
2	71-1419	Joint washer	1	
3	57-4643	Timing pointer	1	
4	70-3821	Countersunk screw	6	
5	70-5976	Chain tensioner abutment	1	(also listed with crankcase group)
6	70-5085	Chain tensioner blade	1	
7	70-4152	Tie rod	1	
8	70-5087	Trunnion	1	
9	70-9703	Adjuster sleeve nut	1	
10	60-4125	Primary chain, $\frac{3}{8}$ in. Triplex x 84 links	1	
11	21-2199	Stator stud	2	
12	21-2198	Stator stud	1	
13	47205	Stator, RM21 (99-1006)	1	
14	70-9360	Sleeve nut	1	
15	70-4144	Rubber grommet	1	
16	60-4247	Plain washer	3	
17	14-0702	Self-locking nut	3	
18	71-1463	Joint washer	1	
19	71-3555	Chaincase	1	
20	57-2440	Rotor cover	1	
21	71-1457	Joint washer	1	
22	57-4672	Screw	3	
23	57-2166	Filler plug	1	
24	70-8782	"O" ring	1	
25	14-6608	Screw	6	
26	14-6620	Screw	2	
27	21-0544	Domed nut	2	
28	82-1880	Copper washer	2	

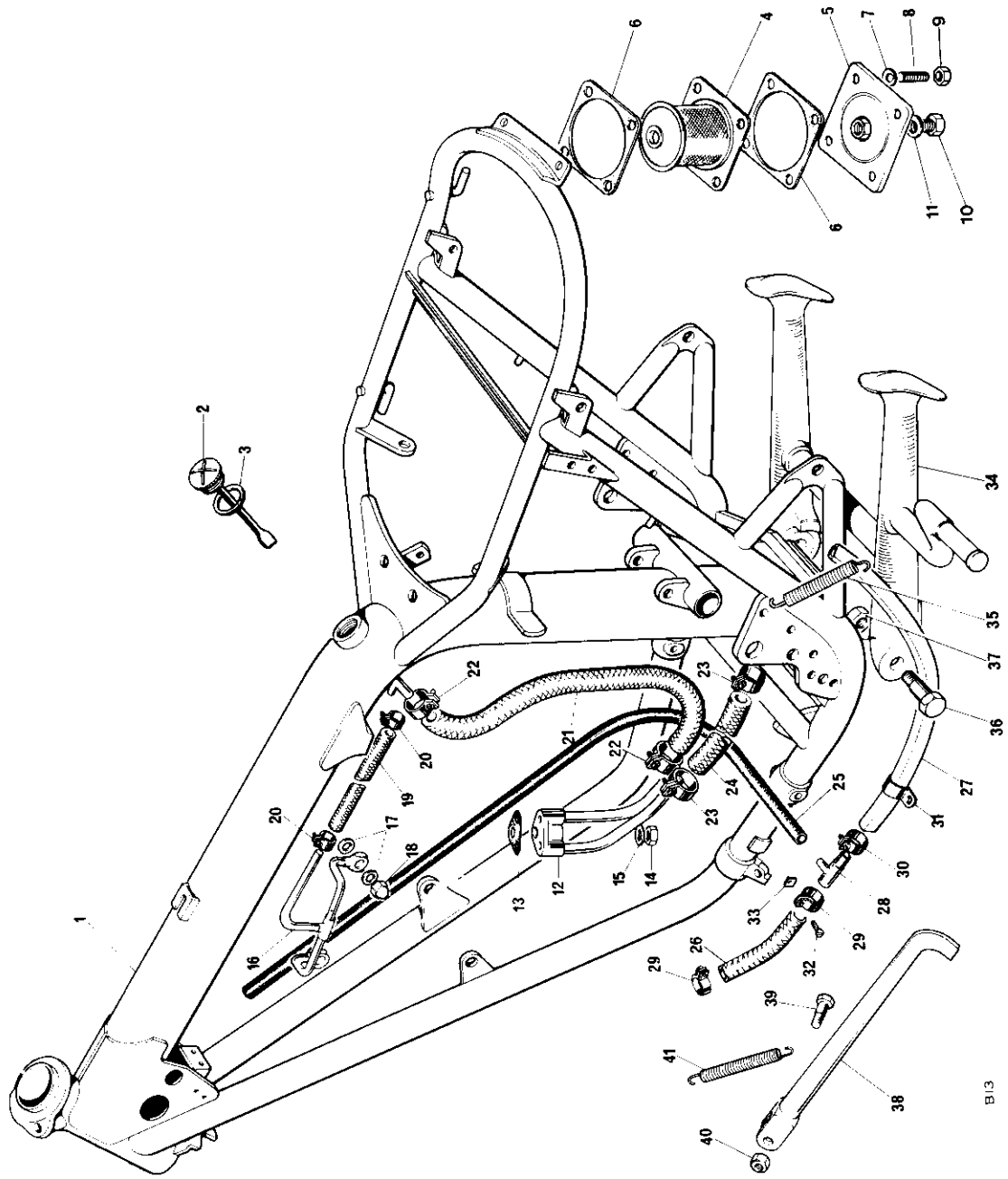

16. FRAME

B13

Ref. No.	Part No.	DESCRIPTION	QUANTITY	REMARKS
FRAME				
1	83-4753	Frame	1	
2	71-3463	Oil filler cap	1	
3	60-3616	"O" ring	1	
4	83-4783	Oil filter	1	
5	71-3316	Sump plate	1	
6	83-2829	Gasket	2	
7	60-2330	Washer	4	
8	21-2025	Stud	4	} Sump plate to frame
9	14-1302	Nut	4	
10	82-5343	Drain plug	1	
11	70-1335	Joint washer	1	
12	71-3478	Oil junction block	1	
13	71-3754	Joint washer	1	
14	21-1908	Nut	1	} Junction block to crankcase
15	70-3446	Washer		
16	71-3550	Rocker oil pipe	1	
17	70-1335	Washer	4	
18	21-0550	Nut	2	
19	71-3551	Rocker feed pipe	1	
20	70-6848	Clip—rocker feed pipe	2	
21	71-2345	Oil return pipe	1	
22	70-6848	Clip—return pipe	2	
23	82-9073	Clip—feed pipe	2	
24	71-3450	Oil feed pipe	1	
25	71-2349	Oil vent pipe	1	
26	83-5285	Crankcase breather pipe—front	1	
27	83-4813	Crankcase breather pipe—rear	1	
28	83-5290	"T" piece	1	
29	60-2252	Clip—breather pipe—front	2	
30	60-2252	Clip—breather pipe—rear	1	
31	83-1615	Clip—breather pipe to fender	4	SCREW 97-3854 NUT 82-4717
32	97-3894	Screw	4	
33	82-4717	Nut	4	
34	83-4615	Centre stand	1	
35	83-3793	Spring	1	
36	21-2077	Pivot bolt	2	
37	14-1304	Nut	2	
38	83-1560	Prop stand	1	
39	82-7021	Bolt	1	
40	14-1303	Nut	1	
41	82-8382	Spring	1	
Not illus.	60-3361	Transfer "Made in England"	1	
Not illus.	14-0114	Bolt	1	} Prop stand stop
Not illus.	14-0402	Nut		

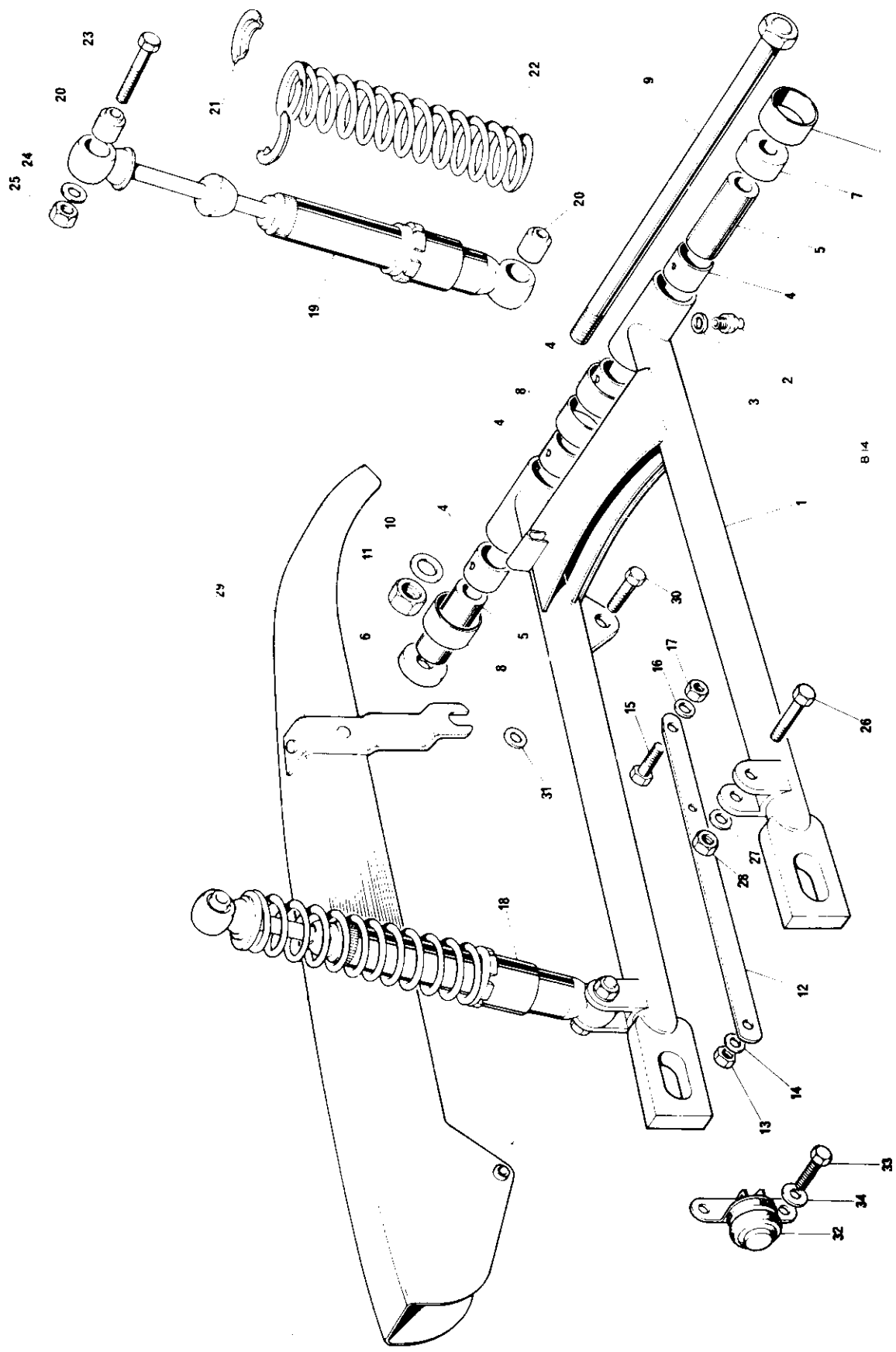

B 14

Fig. 17. SWINGING FORK AND SUSPENSION UNITS

SWINGING ARM AND SUSPENSION UNITS

1	83-2513	SWINGING ARM	1	
2	60-1841	Grease nipple	2	
3	71-2501	Washer, grease nipple	2	
4	83-2521	Bush, pivot arm	4	
5	83-2691	Sleeve, swinging arm pivot	2	
6	83-2690	Distance piece R.H.	1	
7	83-2689	Distance piece L.H.	1	
8	83-2692	Dirt excluder	4	
9	21-2087	Stud, swinging arm pivot	1	
10	83-2266	Washer, swinging arm pivot	2	
11	14-1307	Nut, swinging arm pivot	1	
12	83-2656	Brake torque stay	1	} Also listed with rear wheel
13	14-0305	Nut, torque stay to brake plate	1	
14	60-2431	Washer, torque stay to brake plate	1	
15	14-0133	Bolt, torque stay to swinging arm	1	
16	37-2330	Washer, torque stay to swinging arm	1	
17	14-1304	Nut, torque stay to swinging arm	1	
18	64052564	SUSPENSION UNIT (60-3957)	2	
19	6405263	Damper unit		Reference only
20	64533645	Bonded bush (99-0122)	4	
21	9054/171	Spring retainer (99-0107)	4	
22	64543708	Spring, 110 lbs. chrome (99-1048)	2	
23	14-0235	Bolt, damper—top	2	
24	60-2331	Washer, damper—top	2	
25	14-1303	Nut, damper—top	2	
26	14-0234	Bolt, damper, lower	2	
27	60-2331	Washer damper lower	2	
28	14-1303	Nut damper lower	2	
29	83-2641	Chainguard	1	
30	14-0206	Bolt, chainguard fixing—front	1	
31	60-2347	Washer, chainguard fixing—front	1	
32	34815	Stop lamp switch—118SA (99-1028)	1	
33	60-3550	Screw	2	
34	97-1388	Washer	2	

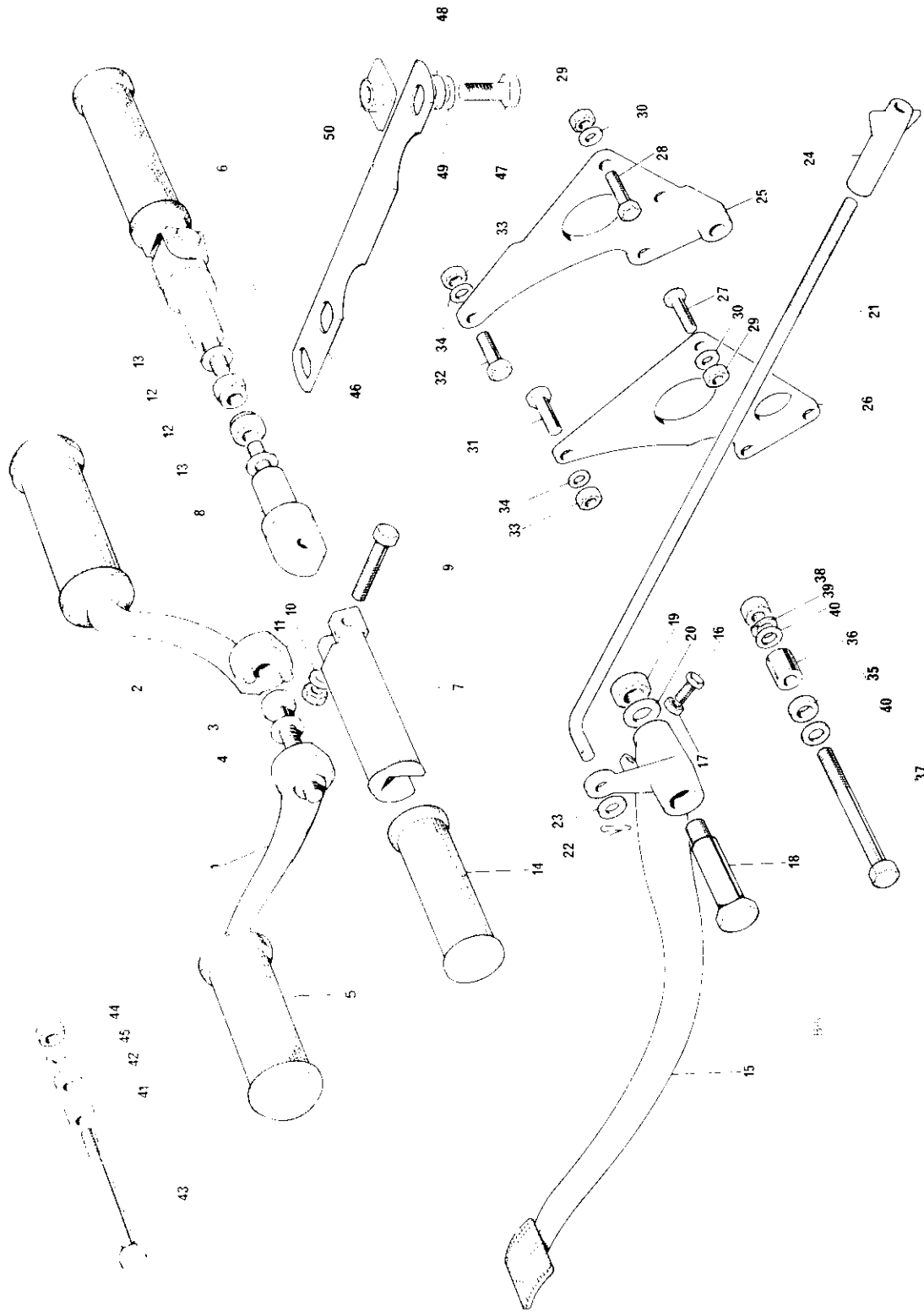

Fig. 18. MOTOR UNIT FITTING AND FOOTRESTS

MOTOR UNIT FITTINGS AND FOOTRESTS

1	83-2854	Footrest—L.H. ...	1	
2	83-2855	Footrest—R.H. ...	1	
3	14-0259	Bolt ...	2	
4	60-2333	Washer ...	2	
5	82-9279	Footrest rubber ...	2	
6	83-2841	PILLION FOOTREST ...	2	
7	82-9053	Pedal ...	1	
8	83-3207	Hanger bolt ...	1	
9	14-0217	Bolt ...	1	
10	82-9089	Washer } Footrest swivel ...	1	
11	14-1302	Nut } ...	1	
12	14-1303	Nut } Footrest to frame ...	1	
13	82-2184	Washer } ...	1	
14	82-9054	Footrest rubber ...	1	
15	83-2666	Rear brake pedal ...	1	
16	14-0103	Screw } Stop light adjustment ...	1	
17	14-0301	Nut } ...	1	
18	21-2045	Pivot pin ...	1	
19	14-1303	Nut ...	1	
20	70-8084	Washer ...	1	
21	83-2860	Rear brake operating rod ...	1	
22	—	Split pin ($\frac{1}{8}$ in. x $\frac{3}{8}$ in.) ...	1	Reference only
23	83-4277	Distance piece ...	1	
24	82-7387	Adjuster nut—brake rod ...	2	
25	83-3024	Rear motor plate R.H. ...	1	
26	83-3023	Rear motor plate—L.H. ...	1	
27	14-0115	Bolt ...	5	
28	14-0116	Bolt } Rear motor plates to frame ...	1	
29	14-1302	Nut } ...	6	
30	60-2330	Washer } ...	12	
31	14-0220	Bolt } Motor to motor plates ...	2	
32	14-0221	Bolt } ...	2	
33	14-1302	Nut } ...	4	
34	60-2321	Washer } ...	8	
35	83-2846	Distance piece—L.H. ...	1	
36	83-2847	Distance piece—R.H. ...	1	
37	21-2112	Bolt } Motor to frame centre bottom ...	1	
38	14-0304	Nut } ...	1	
39	60-4251	Washer } ...	1	
40	60-2332	Washer } ...	2	
41	83-2848	Distance piece—L.H. ...	1	
42	83-2849	Distance piece—R.H. ...	1	
43	14-0254	Bolt } Motor fixing front ...	1	
44	14-1304	Nut } ...	1	
45	60-2332	Washer } ...	1	
46	83-3537	Steady bracket motor to frame ...	1	
47	14-0129	Bolt ...	1	
48	83-3329	Distance piece } Bracket to frame ...	1	
49	60-2331	Washer } ...	1	
50	83-4086	Attachment plate ...	1	
Not illus.	14-1305	Nut } Footrest bolt ...	2	
Not illus.	83-3602	Collar } ...	2	

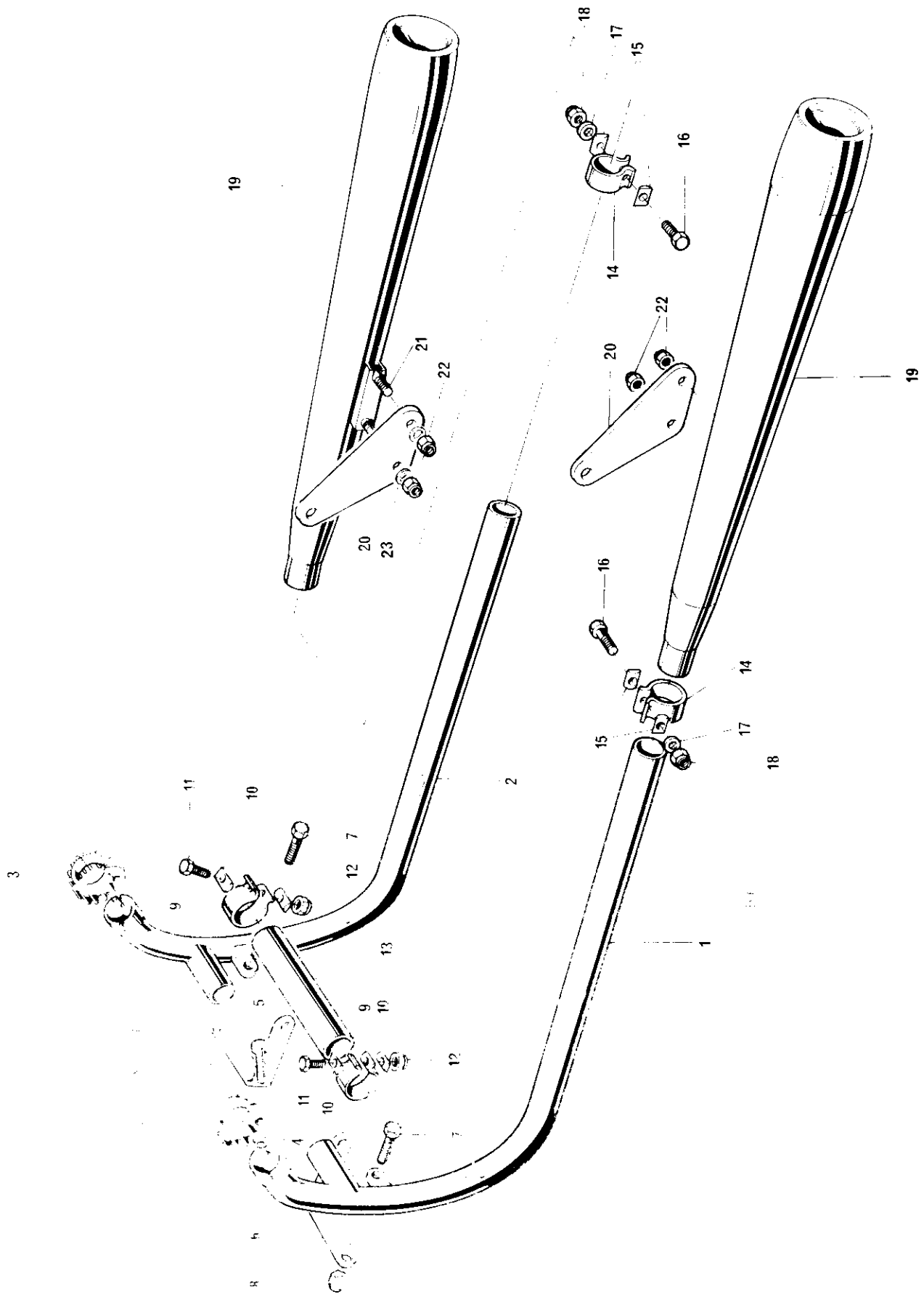
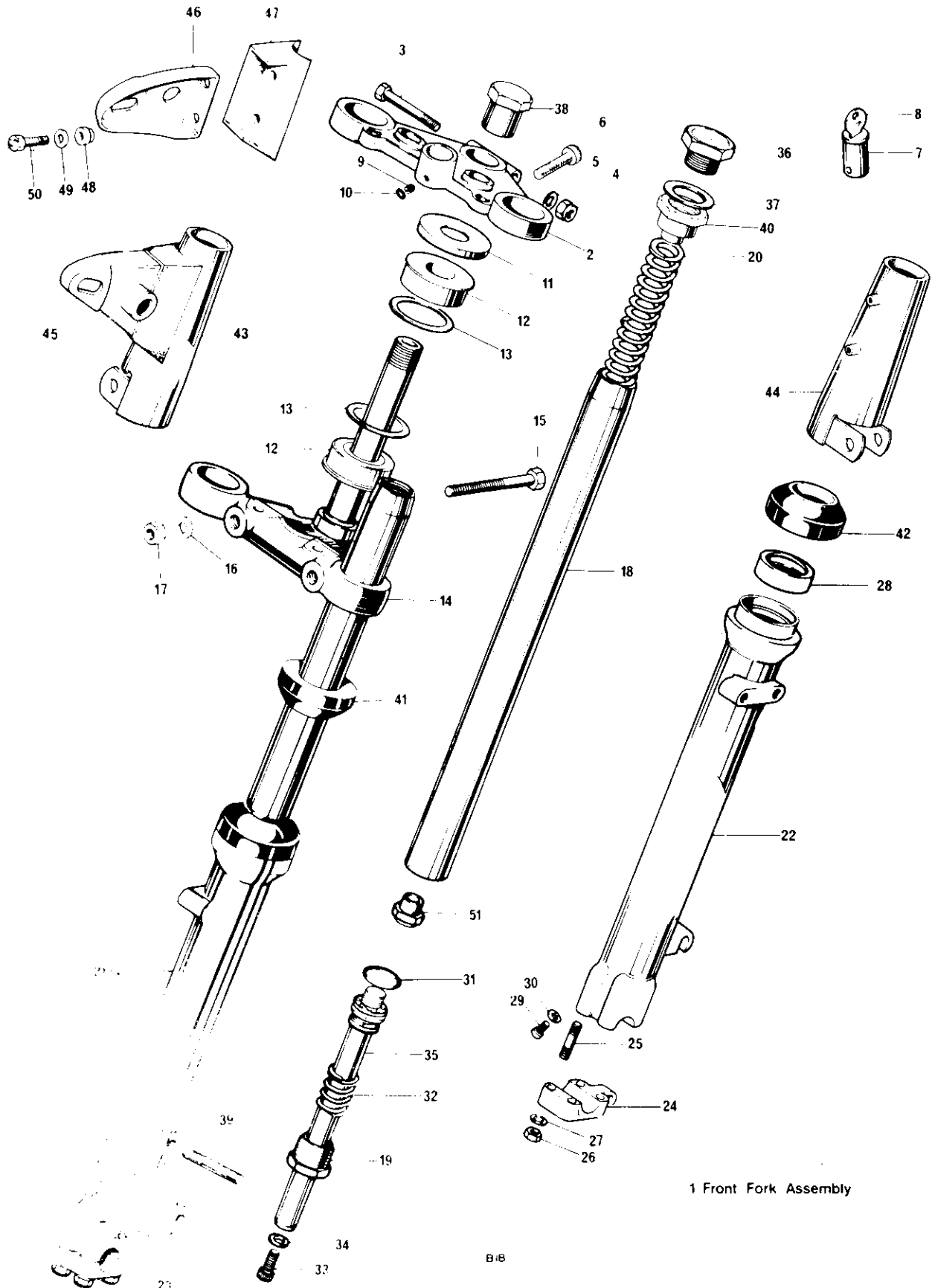

Fig. 19. EXHAUST PIPES AND MUFFLERS

EXHAUST PIPES AND MUFFLERS, TR7RV, T140V

1	71-3755	Exhaust pipe—L.H.	...	1
2	71-3758	Exhaust pipe—R.H.	...	1
3	71-2465	Finned clip	} Exhaust pipes to cylinder head	2
4	21-0778	Nut		2
5	21-2186	Screw		2
6	70-6857	Exhaust pipe stay	...	2
7	14-2205	Screw	...	2
8	70-7471	Nut	...	2
9	70-7512	Clip	} Exhaust pipes to coupling pipe	2
10	70-3768	"D" washer		4
11	14-0217	Bolt		2
12	14-1202	Nut	...	2
13	70-9888	Coupling pipe	...	1
14	70-5874	Clip	} Exhaust pipes to mufflers	2
15	70-3768	"D" washer		4
16	14-0219	Bolt		2
17	60-4247	Washer	...	2
18	14-1202	Nut	...	2
19	71-3999	Muffler	...	2
20	71-3761	Hanger—muffler and pillion footrest	...	2
21	14-0102	Bolt	} Muffler to hanger	4
22	14-1201	Nut		4
23	60-4248	Washer		4



1 Front Fork Assembly

B/B

Fig. 20. TELESCOPIC FRONT FORK

TELESCOPIC FRONT FORK

1	97-4396	FORK ASSEMBLY	1	
2	97-4381	Top Yoke	1	
3	14-0234	Pinch Bolt	1	
4	14-1303	Nut	1	
5	60-2331	Washer	1	
6	14-1034	Cap Screw	2	
7	82-6738	Lock c/w 2 keys	1	
8	60-0623	Key (state serial no.)	1	
9	21-0578	Grub Screw	1	
10	97-2266	Sealing Washer	1	
11	83-2007	Abutment Ring	2	
12	97-4031	Taper roller bearing	2	
13	97-4028	Dust cover	2	
14	97-4385	Bottom yoke and stem	1	
15	14-0237	Pinch bolt	1	
15	97-4476	Pinch bolt	1	
16	82-2184	Washer	4	
17	14-1303	Nut	2	
18	97-4380	Stanchion	2	
19	97-4076	End Plug	2	
20	97-4011	Main Spring	2	
21	97-4514	OUTER MEMBER—L.H.	1	
22	97-4515	OUTER MEMBER—R.H.	1	
23	97-4456	Cap, wheel spindle—L.H.	1	
24	97-4457	Cap, wheel spindle—R.H.	1	
25	21-2102	Stud	8	
26	14-0302	Nut	8	
27	60-2428	Washer	8	
28	97-4001	Oil Seal	2	
29	97-3894	Drain Plug	2	
30	97-3893	Washer	2	
31	97-4003	'O' ring	2	
32	97-4009	Recoil Spring	2	
33	14-1019	Cap Screw	2	
34	97-4004	Cap Screw Seal	2	
35	97-4325	Damper Tube and Valve Assembly	2	
36	97-4395	Top Cap Nut	2	
37	97-4166	Washer	2	
38	97-4317	Steering Stem Nut	1	
39	21-2189	Stud, Caliper to Outer Member	2	
40	97-4387	Cap Screw, Top Cap Nut	2	
41	97-4461	Rubber Ring, Outer Cover	2	
42	97-4002	Scraper Sleeve	2	

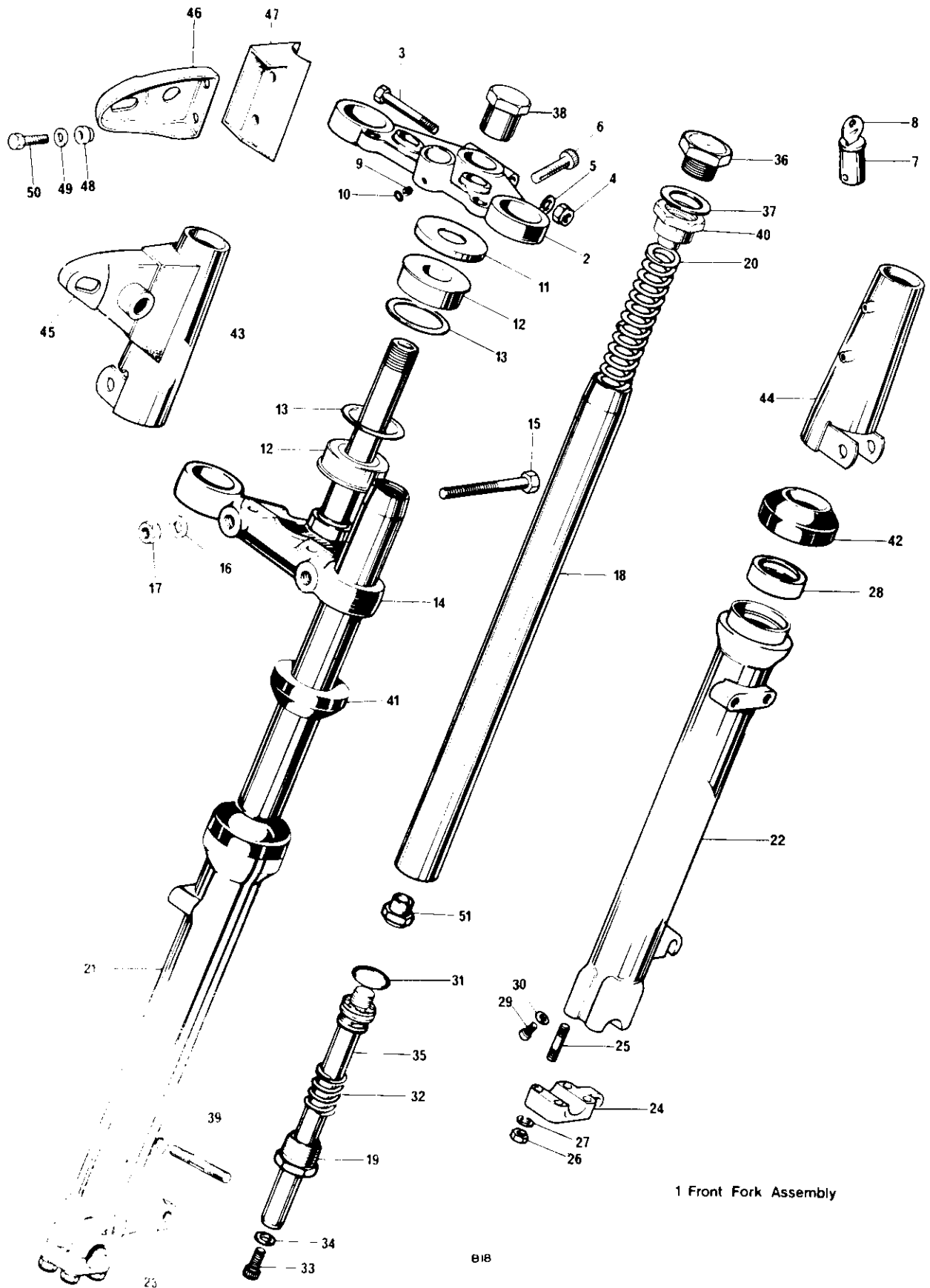

1 Front Fork Assembly

Fig. 20. TELESCOPIC FRONT FORK

Ref. No.	Part No.	DESCRIPTION	QUANTITY	REMARKS
----------	----------	-------------	----------	---------

TELESCOPIC FRONT FORK (continued)

43	97-4480	Outer cover—L.H.	1	
44	97-4481	Outer cover—R.H.	1	
45	97-4121	Headlamp bracket—L.H.	1	
46	97-4203	Headlamp bracket—R.H.	1	
47	97-2208	Rubber mounting	2	
48	97-2209	Rubber buffer	4	
49	97-2210	Backing washer	4	
50	21-2095	Attachment bolt	4	
Not illus.	82-6784	Grommet, throttle cable	1	
51	97-4012	Nut, damper valve	1	

ALTERNATIVE FITMENTS (NOT U.S.A.)

97-1510	Gaiter—fork outer cover	2	
97-4406	Outer cover—L.H.	1	
97-4407	Outer cover—R.H.	1	

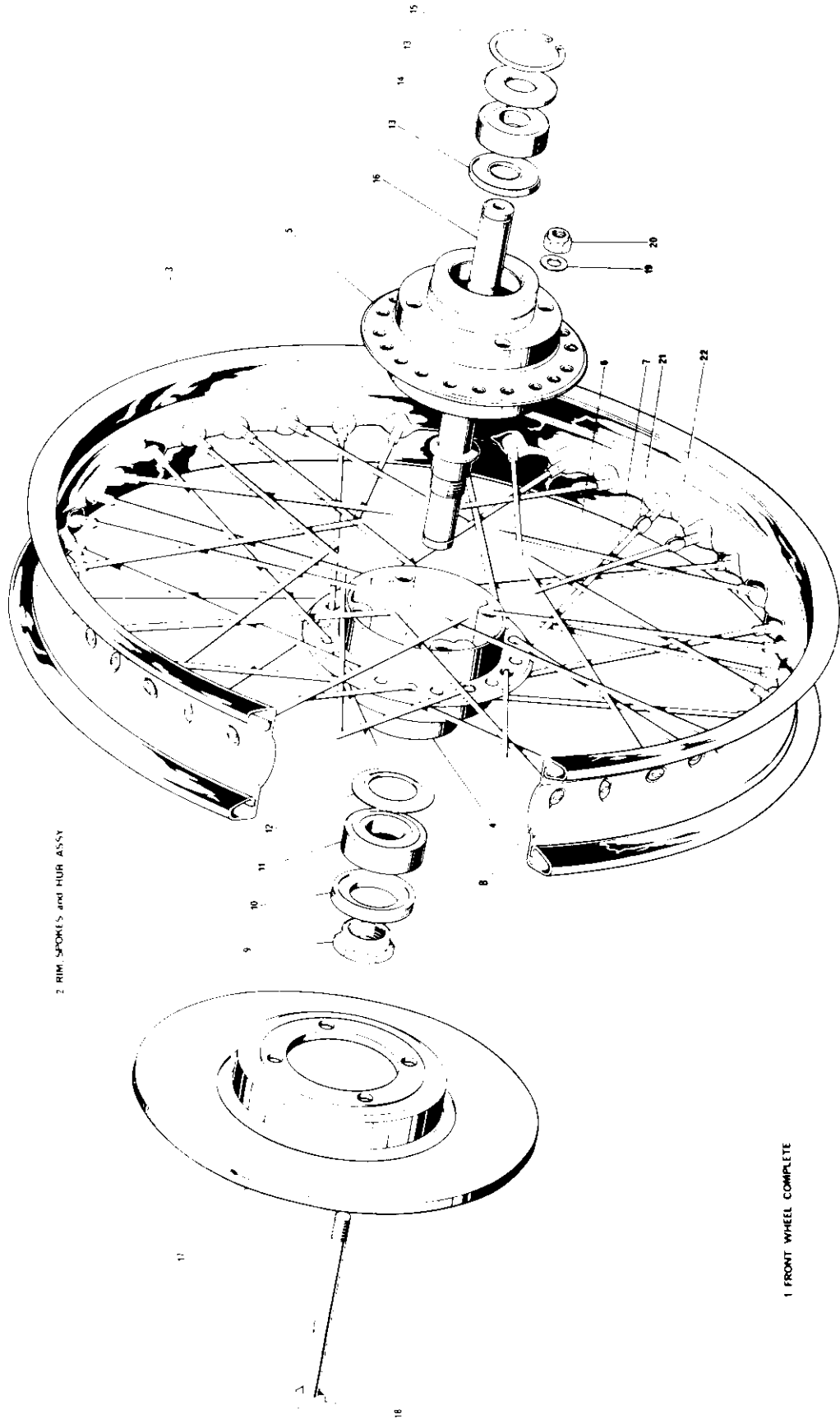

2 RIM, SPOKES and HUB ASSY

1 FRONT WHEEL COMPLETE

Fig. 22 FRONT WHEEL

FRONT WHEEL

Ref. No.	Part No.	Description	Quantity	Remarks
1	37-4141	FRONT WHEEL COMPLETE	1	
2	37-4143	RIM, SPOKES AND HUB ASSEMBLY	1	
3	37-4129	Rim	1	
4	37-4126	Hub—L.H. half	1	
5	37-4127	Hub—R.H. half	1	
6	37-4131	Spoke—Outer	20	
7	37-4130	Spoke—Inner	20	
8	37-2294	Spoke Nipple	40	
9	37-4133	Locknut—L.H.	1	
10	37-4134	Lock Ring—L.H.	1	
11	57-1070	Bearing—L.H.	1	
12	37-4135	Grease retainer—L.H.	1	
13	37-1237	Dust Cover—R.H.	2	
14	37-0653	Bearing—R.H.	1	
15	57-0280	Circlip— R.H.	1	
16	37-4132	Spindle	1	
17	37-4136	Disc	1	
18	21-2207	Bolt	4	
19	60-2322	Washer	4	} Disc to hub
20	14-1303	Nut	4	
21	37-3969	Balance weight	As reqd.	
22	37-3970	Balance weight	As reqd.	

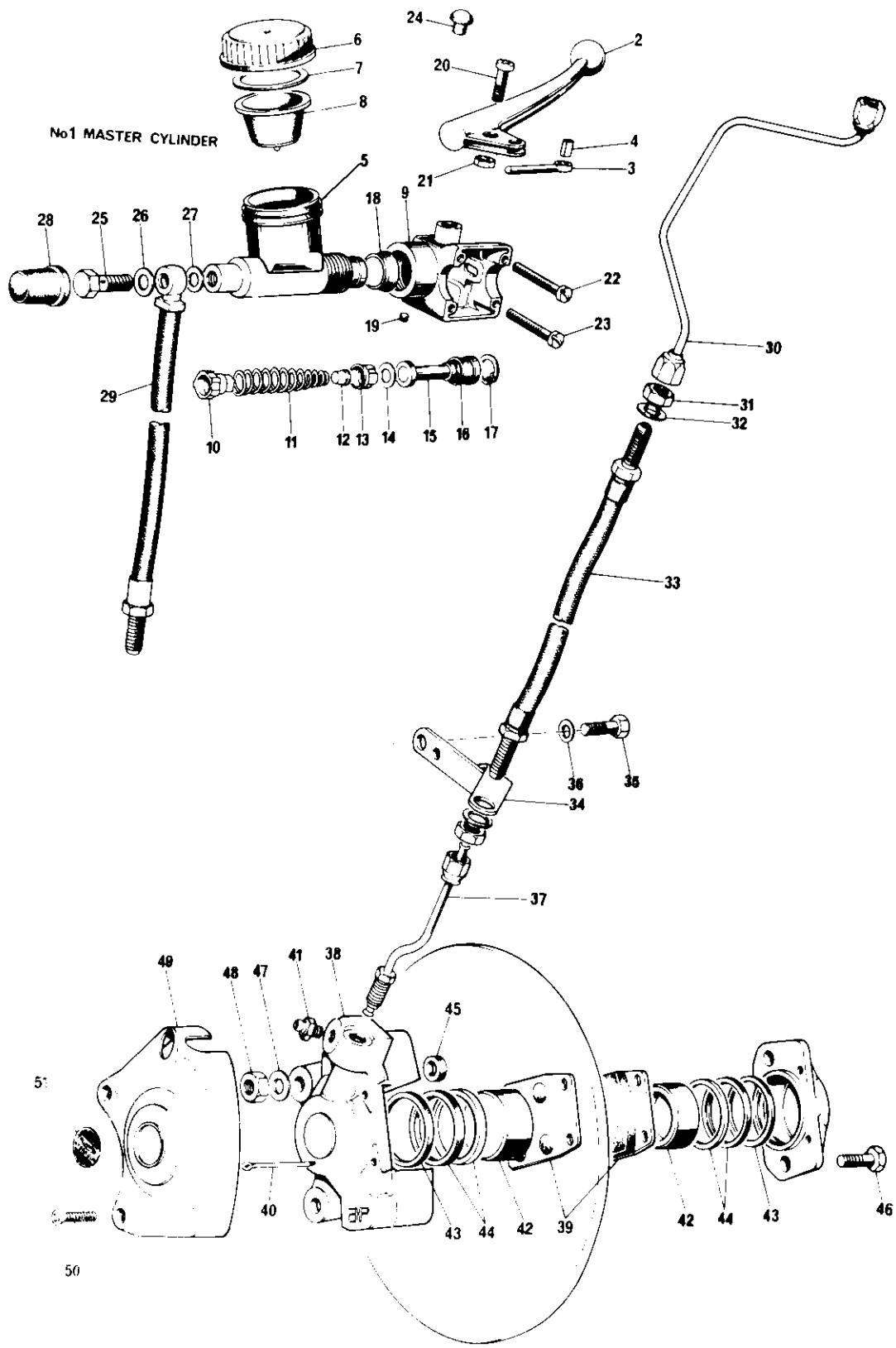

Fig. 23. FRONT BRAKE

Ref. No.	Part No.	DESCRIPTION	QUANTITY	REMARKS
FRONT BRAKE				
1	4222-979	MASTER CYLINDER (60-4102)	1	
2	60-4206	Brake lever assembly	1	
3	3761-270	Piston	1	Reference only
4	3528-441	Spiral pin	1	Reference only
5	4221-072	Barrel and tank assembly (99-2770)	1	
6	3847-240	Cap (99-2751)	1	
7	60-4328	Washer	1	
8	*3818-747	Diaphragm (99-2752)	1	
9	3338-901	Switch housing (99-2753)	1	
10	*4312-318	Trap valve (99-2754)	1	
11	3118-234	Spring (99-2755)	1	
12	3675-216	Spring retainer (99-2756)	1	
13	*3842-424	Primary cup (99-2757)	1	
14	*106418	Piston washer (99-2758)	1	
15	3261-542	Piston (99-2759)	1	
16	*3871-473	Secondary cup (99-2760)	1	
17	K29103	Circlip (99-2761)	1	
18	*3811-420	Rubber boot (99-2762)	1	
19	3476-209	Grub screw (99-2763)	1	
20	21-2191	Pivot screw	1	
21	14-1201	Nut	1	
22	21-2192	Screw	2	} Switch assembly to housing
23	21-2194	Screw	2	
24	70-7573	Plug	1	
25	30420	Banjo bolt (60-4183)	1	
26	KL44516	Sealing washer (60-4182)	1	
27	KL44518	Sealing washer (60-4184)	1	
28	60-4186	Rubber boot	1	
29	KL58505	Hose, master cylinder to top yoke (60-4176) used with high handlebar	1	
29	KL563	Hose, master cylinder to top yoke (60-4177) used with low handlebar	1	
30	ZT2071N	Pipe, top yoke to bottom yoke (60-4179)	1	
31	K24103	Locknut (60-4180)	3	
32	K19407	Washer (60-4181)	3	
33	KL56612	Hose, bottom yoke to fork leg (60-4175)	1	
34	83-5150	Bracket, pipe support	1	
35	14-0103	Bolt	2	} Bracket to fork leg
36	60-2427	Washer	2	
37	ZTA2070N	Pipe, fork leg to caliper (60-4178)	1	
38	4823-432	CALIPER (60-4101)	1	
39	†4741-537	Brake pad	1	Reference only
40	†K19866TP2	Retaining pin	1	Reference only
41	3486-229	Bleed nipple (99-2764)	1	
42	3275-428	Piston (99-2765)	2	
43	96498	Fluid seal (99-2766)	2	
44	SSB72075	Retainer (99-2767)	2	
45	102799	Fluid seal	1	Reference only
46	3437-307	Bolt, caliper halves	1	Reference only
47	60-2331	Washer	2	} Caliper to outer member
48	14-1303	Nut	2	
49	37-4170	Cover, caliper	2	
50	21-2196	Screw, cover attachment	2	
51	60-4156	Decal, caliper cover	1	

* Master cylinder repair kit 99-2768

† Brake pad kit 99-2769



Fig 24. REAR WHEEL

REAR WHEEL

1	37-3968	REAR WHEEL COMPLETE	1	
2	37-4182	RIM SPOKES AND HUB ASSEMBLY	1	
3	37-3784	Rim	1	
4	37-3724	Spoke (inner—L.H.)	10	
5	37-3725	Spoke (outer—L.H.)	10	
6	37-3726	Spoke—R.H.	20	
7	37-2294	Nipple... ..	40	
8	37-4179	Hub and brake drum	1	
9	37-3468	Tyre security bolt... ..	2	
10	37-3749	Support ring—L.H.	1	
11	37-0653	Bearing	2	
12	37-4181 37-3749	Locking ring—L.H.	1	
13	37-4180	Spacer	1	
14	37-3753	Spacer	1	
15	37-1654	Grease retainer—R.H.	1	
16	37-3747	Sprocket 47 teeth	1	
17	14-0207	Bolt	5	
18	60-2320	Washer } Sprocket to hub	5	
19	14-1301	Nut }	5	
20	37-3856	Brake anchor plate	1	
21	37-4145	Brake cam	1	
22	37-4147	Brake lever	1	
23	14-1303	Nut	1	
24	60-2331	Washer	1	
25	37-3870	Brake pivot	1	
26	14-0305	Nut } Brake pivot to torque arm	1	
27	60-2431	Washer }	1	
28	37-3925	Brake shoe complete (leading)	1	
29	37-3926	Brake shoe complete (trailing)	1	
30	37-2328	Return spring (brake shoe)	2	
31	37-4049	Return spring (brake lever)	1	
32	83-2656	Brake torque arm	1	
33	14-0133	Bolt	1	
34	37-2330	Washer } Torque arm to frame	2	
35	14-1304	Nut }	1	
36	37-3965	Wheel spindle	1	
37	37-3750	Distance piece inner	1	
38	60-3213	Speedometer drive gearbox	1	
39	37-3746	Distance piece outer	1	
40	14-1307	Nut } Wheel spindle	1	
41	83-2266	Washer }	1	
42	37-3751	Speedometer drive ring	1	
43	83-3082	Cover plate—swinging arm fork end	2	
44	37-3742	Chain adjuster	2	
45	14-0107	Screw } Chain adjuster	2	
46	14-0301	Nut }	2	
47	60-1841	Grease nipple	1	
48	71-2501	Fibre washer	1	

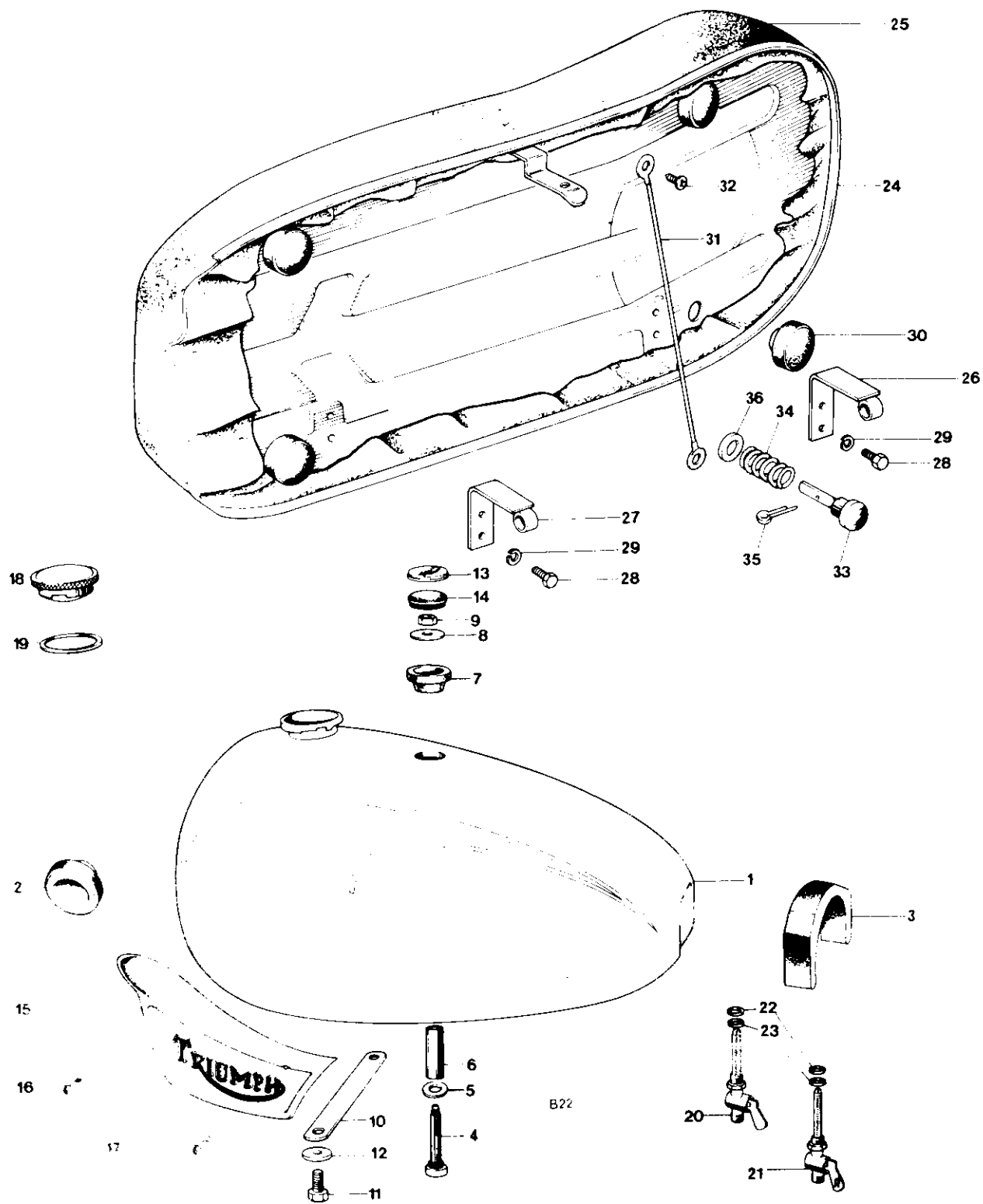

Fig. 25 GAS TANKS AND TWINSEAT

GAS TANK AND TWINSEAT

1	83-5413	Gas tank (3-6 U.S. galls.)	1	T140V
1	83-5414	Gas tank (3-6 U.S. galls.)	1	TR7RV
2	83-4931	Steady rubber	2	
3	83-4932	Mounting rubber	2	
4	83-4930	Centre fixing bolt	1	
5	60-2321	Washer	1	
6	82-9063	Distance tube	1	
7	83-4934	Mounting rubber	1	
8	83-3814	Washer	1	
9	14-1202	Nut	1	
10	83-4395	Tie strap	1	
11	14-0113	Bolt	1	
12	60-2428	Washer	1	
13	83-4776	Badge—tank grommet	1	
14	83-4763	Grommet	1	
15	82-9700	Tank motif—L.H.	1	
15	82-9701	Tank motif—R.H.	1	
16	83-1339	Screw—front—tank motif	2	
17	82-7888	Screw—rear—tank motif	2	
18	83-3875	Filler cap	1	
19	82-4048	Joint washer	1	
20	83-2800	Gas tap	1	
21	83-2801	Gas tap—reserve	1	
22	70-7351	Tap seal	2	
23	83-0002	Washer	2	
24	83-4786	Twinseat	1	
25	83-4789	Twinseat cover	1	
26	83-4782	Hinge—rear	1	
27	83-4802	Hinge—front	1	
28	14-0101	} Hinge attachment	4	
29	60-2417		Washer	4
30	82-9093	Rubber buffer	4	
31	60-2087	Check wire	1	
32	60-2381	Screw—self-tapping	1	
33	82-7560	Seat plunger	1	
34	82-4228	Spring	1	
35	—	Split pin ($\frac{3}{32}$ in. x $\frac{1}{2}$ in.)	1	Reference only
36	70-1719	Washer	1	

ALTERNATIVE FITMENTS

(NOT U.S.A.)

83-5418	Petrol tank (4 Imp. galls.)	1	T140V
83-5417	Petrol tank (4 Imp. galls.)	1	TR7RV
83-4933	Mounting rubber	1	
21-2064	Screw—tank badge	4	
60-2569	Tank badge	2	
83-4355	Knee grip—L.H.	1	
83-4356	Knee grip—R.H.	1	
83-4118	Tie strap	1	

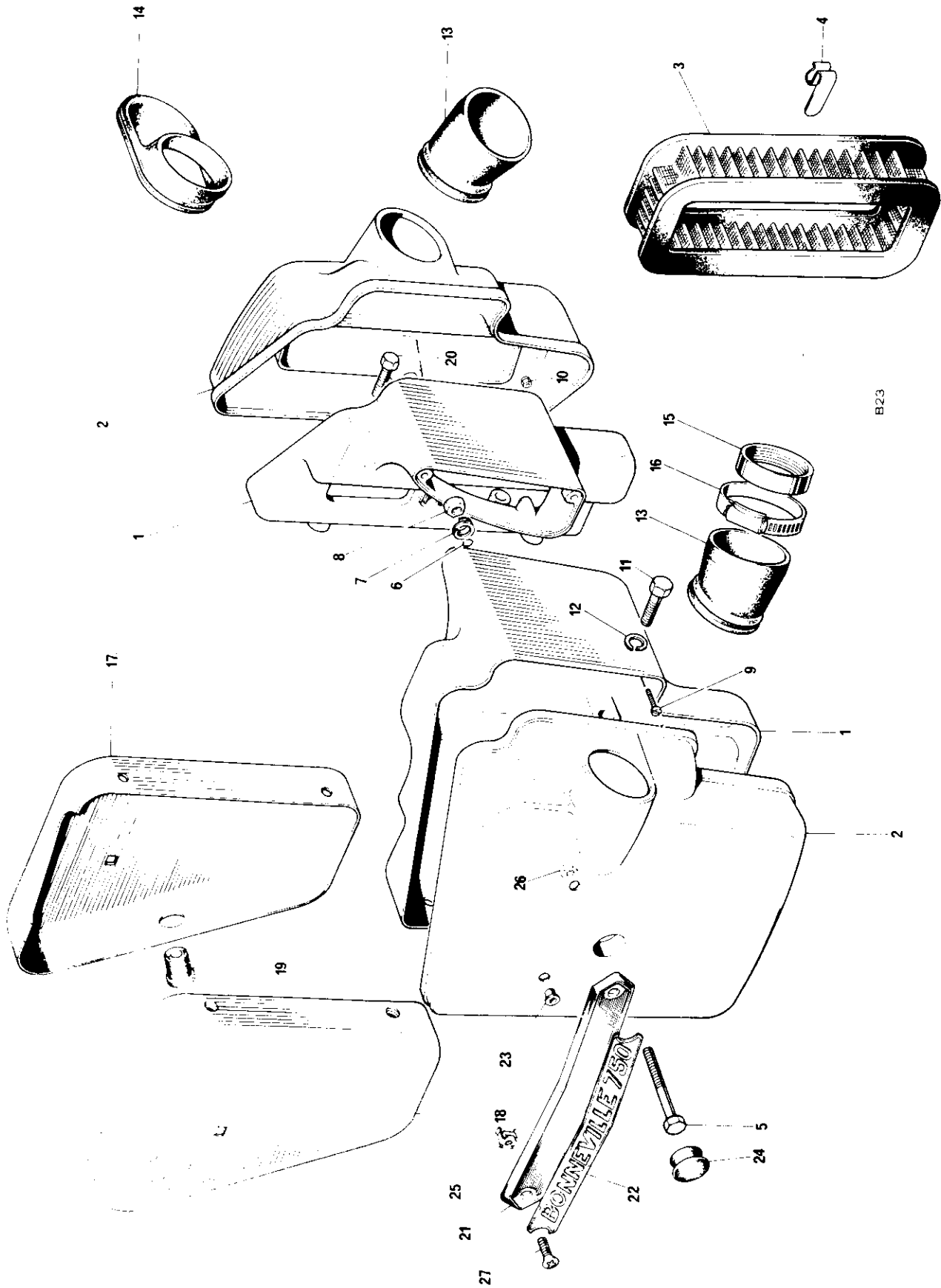

Fig. 26 AIR CLEANERS AND SIDE PANELS

AIR CLEANER AND SIDE PANELS

Ref. No.	Part No.	DESCRIPTION	QUANTITY	REMARKS
	83-5010	AIR CLEANER ASSEMBLY—L.H.	1	Twin Carb T140V
	83-5011	AIR CLEANER ASSEMBLY—R.H.	1	
1	83-4606	Body—L.H.	1	
1	83-4607	Body—R.H.	1	
2	83-4809	Cover—L.H.	1	Single Carb TR7RV
2	93-4810	Cover—R.H.	1	
	33-5012	AIR CLEANER ASSEMBLY—L.H.	1	
	83-5013	AIR CLEANER ASSEMBLY—R.H.	1	
1	83-4845	Body—L.H.	1	All models
1	83-4609	Body—R.H.	1	
2	83-4807	Cover—L.H.	1	
2	83-4808	Cover—R.H.	1	
3	60-3618	Element	2	
4	83-3417	Clip, element	4	
5	14-0221	Bolt	2	
6	82-8245	Retainer	2	
7	60-2438	Washer	2	
8	14-0302	Nut	2	
9	60-3539	Screw	2	
10	21-0501	Nut	2	
11	14-0218	Bolt	2	
12	60-2418	Spring washer	2	
13	83-2626	Connector pipe	2	T140V
14	83-5161	Connector pipe	1	TR7RV
15	71-1860	Carburetor adaptor	1 or 2	
16	60-3975	Clip	1 or 2	
17	83-4854	Side panel—L.H.	1	
18	83-4803	Side panel—R.H.	1	
19	82-6673	Panel grommet	2	
20	14-0102	Bolt	4	
21	60-4150	Name plate	2	
22	60-4169	Motif	2	TR7RV
22	60-4148	Motif	2	T140V
23	60-4153	Rubber bush	2	
24	60-4152	Rubber plug	2	
25	60-4154	'Spire' nut	2	
26	82-4717	Nut	2	
27	82-4129	Screw	2	
Not illus.	83-5236	Rubber strip—side panel	2	

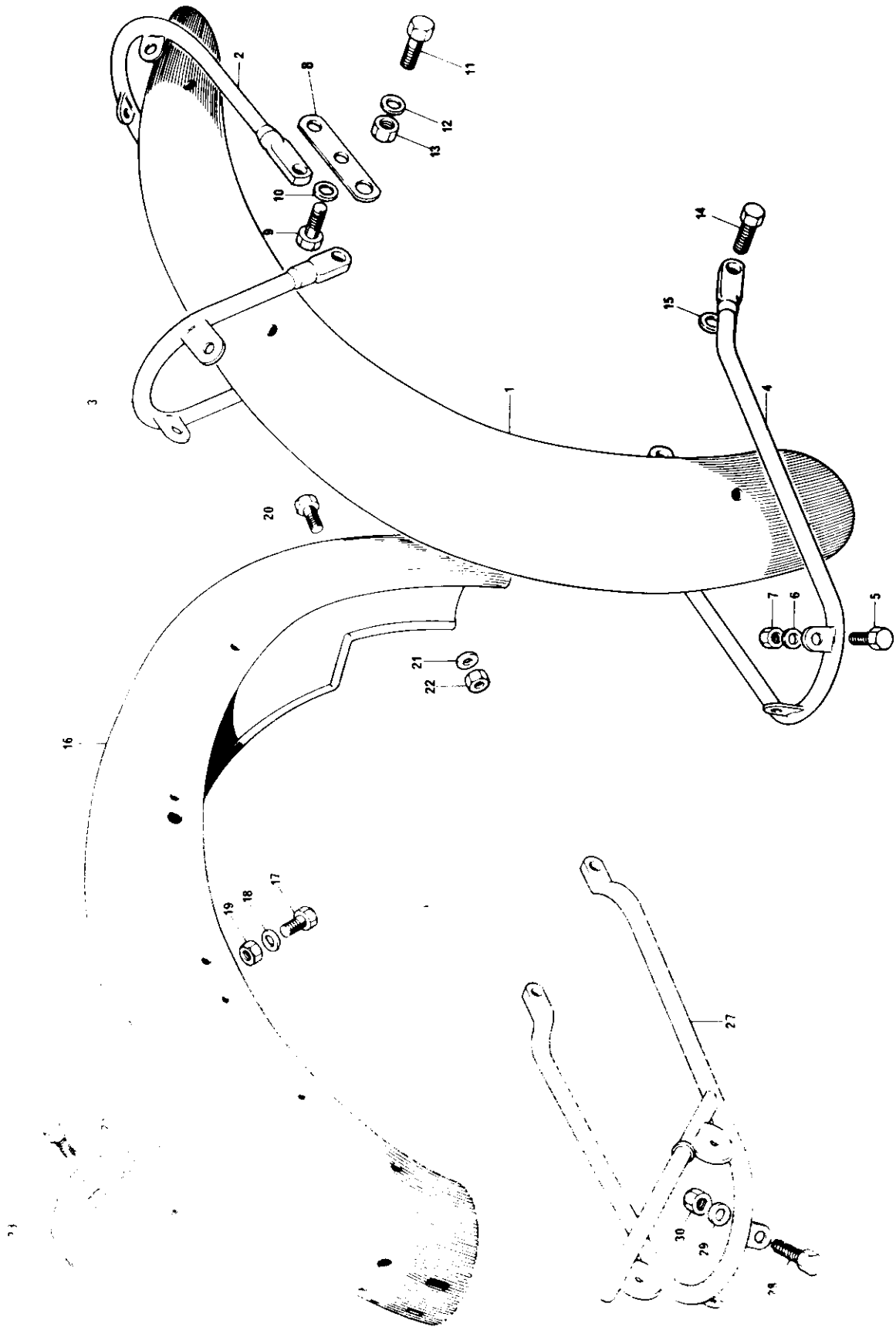

Fig. 27. FENDERS AND TAIL LAMP

F E N D E R S

1	97-4439	Front fender	1
2	97-4533	Front stay	1
3	97-4534	Centre stay	1
4	97-4535	Bottom stay	1
5	14-0101	Bolt	6
6	60-4245	Washer	6
7	14-1201	Nut	6
8	83-5151	Bracket	1
9	14-0103	Bolt	2
10	60-2427	Washer	2
11	14-0116	Bolt	2
12	60-2330	Washer	2
13	14-1302	Nut	2
14	14-6114	Bolt	2
15	60-2428	Washer	2
16	83-4805	Rear fender	1
17	14-0101	Bolt	2
18	60-2329	Washer	2
19	14-1301	Nut	2
20	14-0114	Bolt	2
21	60-2330	Washer	2
22	14-1302	Nut	2
23	83-4600	Bridge—rear fender	1
24	14-0102	Bolt	2
25	60-2329	Washer	2
26	14-1301	Nut	2
27	83-5145	Lifting handle	1
28	14-0102	Bolt	2
29	60-2329	Washer	2
30	14-1301	Nut	2
Not illus.	97-0961	Cable grommet	5

ALTERNATIVE FITMENTS (NOT U.S.A.)

97-4440	Front mudguard	1
83-4823	Front number plate	1
57-1076	Screw	} Number plate attachment	2
71-2448	"O" ring		2	
60-4249	Washer		2	
83-2726	Rear number plate	1
14-0101	Bolt	} Number plate attachment	4
60-2329	Washer		4	
14-1301	Nut		4	

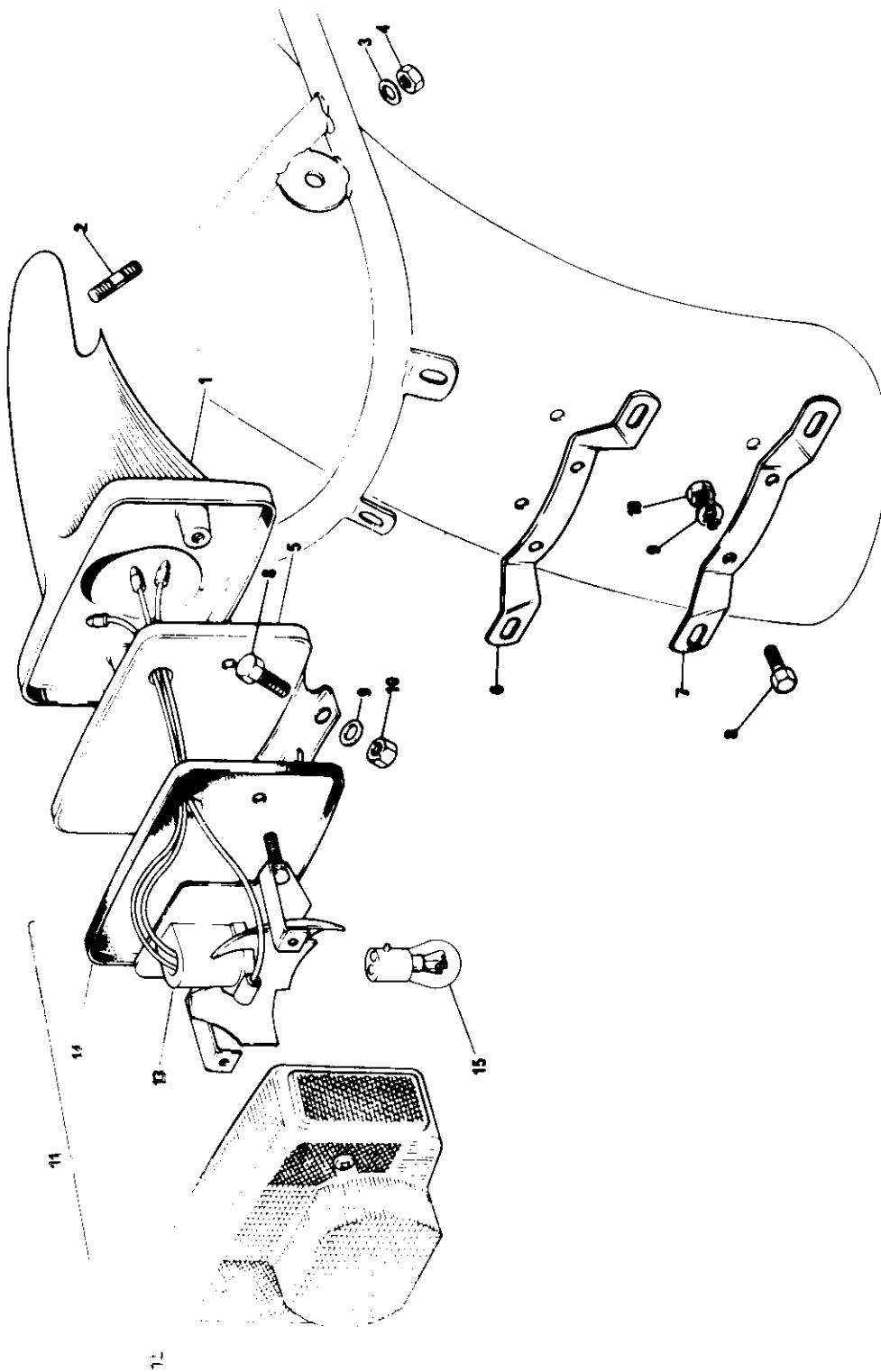

C56

Fig. 28. TAIL LAMP AND SUPPORT

Ref. No.	Part No.	DESCRIPTION	QUANTITY	REMARKS
----------	----------	-------------	----------	---------

TAIL LAMP AND SUPPORT

1	83-4774	Tail lamp support	1	
2	21-2225	Stud	1	
3	60-4250	Washer	1	} Tail lamp support to fender
4	14-0301	Nut		
5	83-5001	Support plate	1	
6	83-4784	Rear no. plate bracket—top	1	
7	82-6850	Rear bo. plate bracket—bottom	1	
8	14-0102	Bolt	4	} No. plate brackets and support plate to fender
9	60-2329	Washer		
10	14-1301	Nut		
Not illus.	83-4806	Wiring protector	1	
11	56513	STOP—TAIL LAMP—L917 (99-1252)	1	
12	54584930	Lens (complete with screws) (99-1257)	1	
13	54534931	Base assembly		Reference only
14	54583924	Gasket		Reference only
15	380	Bulb (99-0542)	1	
Not illus.	60-4103	Cable grommet	5	
Not illus.	60-3748	Decal '5 SPEED'	1	
Not illus.	83-5105	Grommet	2	

60-3579

T/L. SCREW

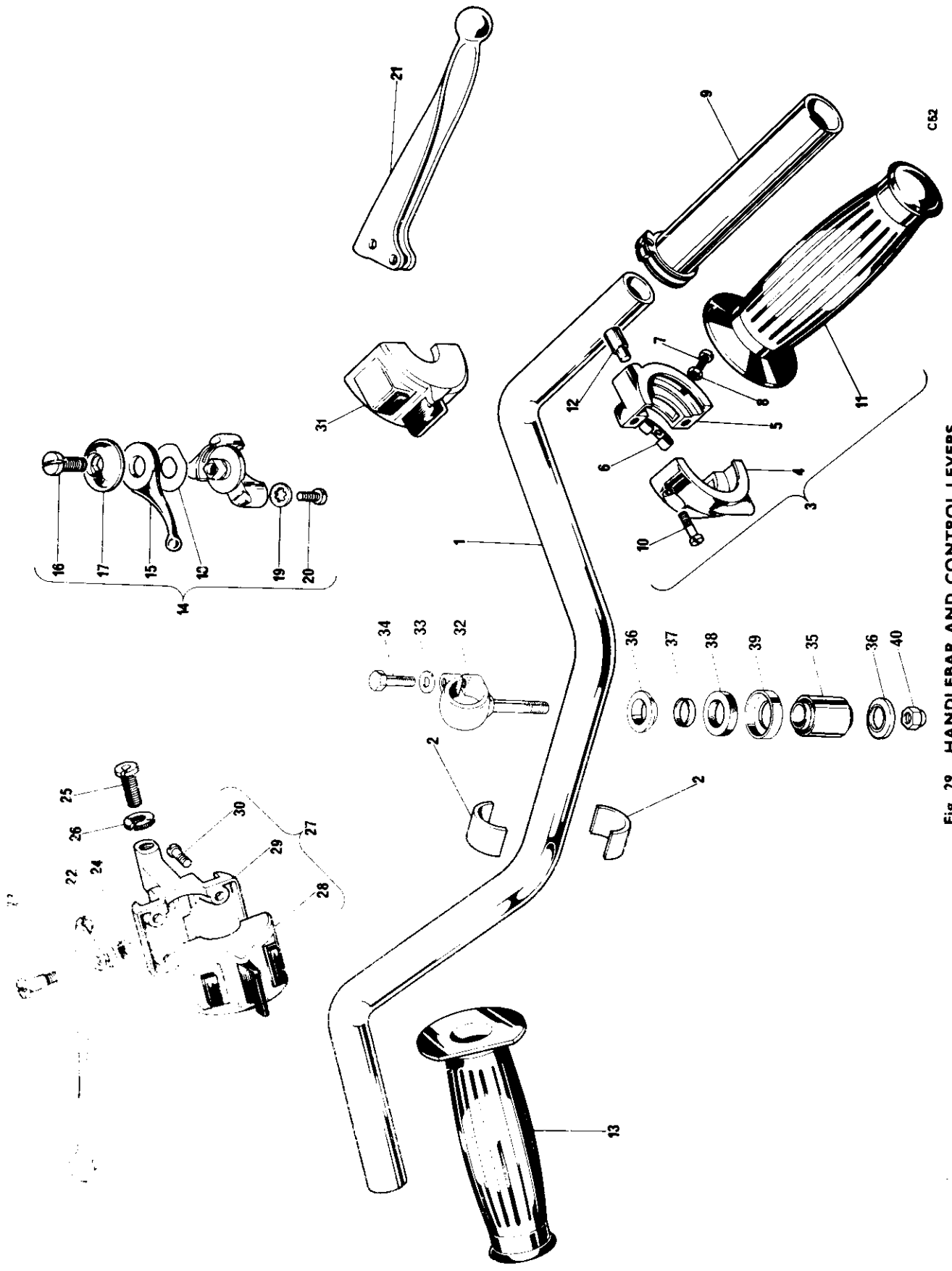

C52

Fig. 29. HANDLEBAR AND CONTROL LEVERS

HANDLEBARS AND CONTROL LEVERS

1	97-4411	Handlebar (high)	1	
1	97-4300	Handlebar (low)	1	Alternative
2	97-1425	Sleeve, handlebar mounting	4	
3	16/364	TWISTGRIP (99-0248)	1	
4	16/328	Body, top half (99-0245)	1	
5	16/329	BODY, BOTTOM HALF (99-0246)	1	
6	16/008	Friction spring	1	Reference only
7	16/009	Screw	1	Reference only
8	16/010	Locknut	1	Reference only
9	99-0244	Rotor	1	
10	11/013	Screw (99-0225)	2	
11	97-0958	Grip	1	
12	16/011	Cable stop (99-0241)	1	
13	97-2124	Grip	1	
14	60-3567	AIR CONTROL LEVER	1	
15	12/556	Lever	1	Reference only
16	12/607	Bolt	1	Reference only
17	12/606	Cap	1	Reference only
18	12/033	Spring washer	1	Reference only
19	60-4256	Shakeproof washer	2	
20	60-3896	Screw	2	
21	*60-4391	Front brake lever	1	Reference only
22	60-3981	Clutch lever	1	
23	21-2048	Pivot pin	1	
24	14-1201	Nut	1	
25	60-3585	Adjuster	2	
26	60-3586	Lockring	2	
27	39595	HANDLEBAR SWITCH—L.H.	1	Reference only
28	54033666	Switch half (99-1235)	1	
29	54340882	Lever half (99-1187)	1	
30	54115246	Screw (99-1188)	4	
31	54033751	Handlebar switch—R.H. (99-1268)	1	
32	97-2291	Handlebar eyebolt	2	
33	82-1335	Washer	2	
34	21-0589	Bolt	2	
35	97-1527	Metalastic bush	2	
36	97-1529	Hemispherical washer	4	
37	97-1581	Distance piece	2	
38	97-1580	Rubber washer	2	
39	97-2221	Cup	2	
40	14-1303	Nut	2	

*Front brake and master cylinder details are shown on page 57

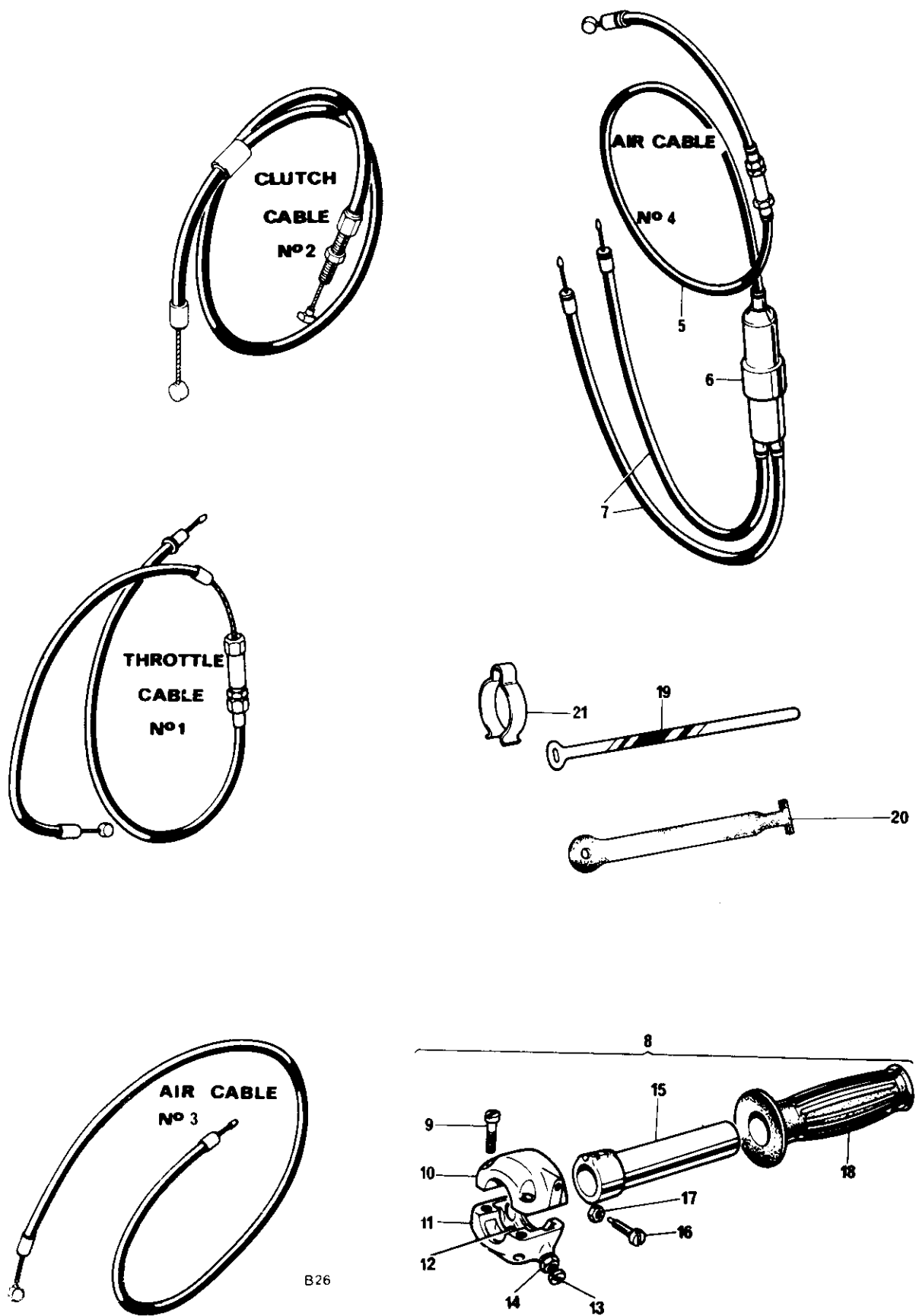

Fig. 30. CONTROL CABLES

CONTROL CABLES

1	60-1819	Throttle cable	2	T140V
1	60-1806	Throttle cable	1	TR7RV
2	60-3925	Clutch cable	1	
3	60-4194	Air control cable	1	TR7RV
4	60-4126	AIR CONTROL CABLE	1	T140V
5	60-4127	Cable, lever to junction box	1	
6	244/104	Junction box (99-0341)	1	
7	60-4128	Cable, junction box to carburetor	2	
8	313/13	TWIN ROTOR TWISTGRIP (99-0347)	1	T140V
9	18/084	Screw		Reference only
10	313/020	Body, top half		Reference only
11	313/021	BODY, BOTTOM HALF		Reference only
12	16/008	Friction spring		Reference only
13	210/007	Screw		Reference only
14	5/077	Nut		Reference only
15	313/004	Rotor		Reference only
16	210/008	Rotor stop screw		Reference only
17	5/077	Nut—rotor stop screw		Reference only
18	97-2125	Grip	1	
19	60-0777	Cable clip	2	
20	60-4258	Cable clip	15	
21	97-4112	Handlebar clip	4	

ALTERNATIVE FITMENTS (NOT U.S.A.)

60-0732	Throttle cable	1	T140V
60-0746	Throttle cable	1	TR7RV
60-4168	Clutch cable	1	

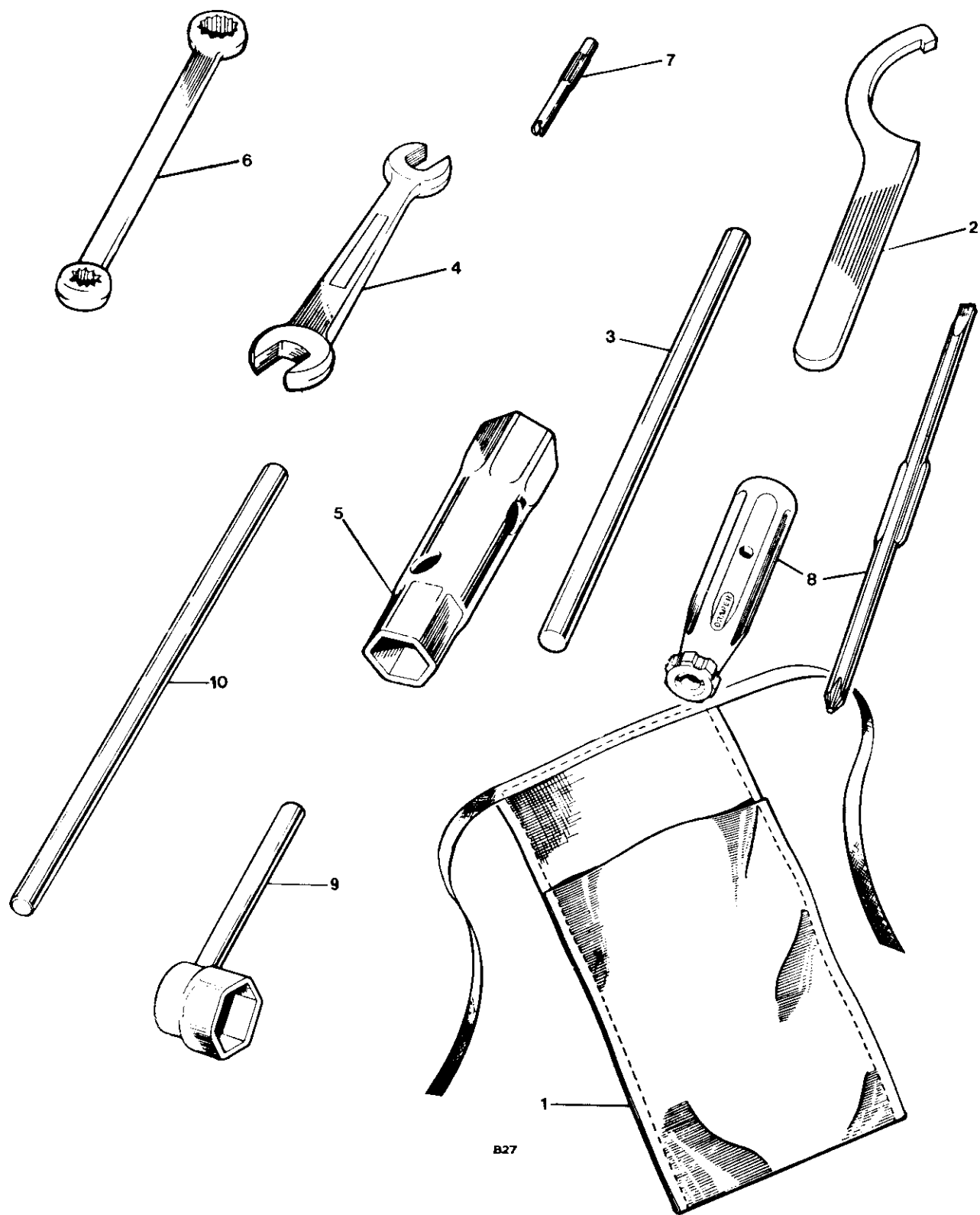

B27

Fig. 31. TOOLKIT

Ref. No.	Part No.	DESCRIPTION	QUANTITY	REMARKS
TOOLKIT				
	60-2112	TOOLKIT COMPLETE	1	
1	60-0291	Tool roll	1	
2	60-2184	Damper unit spanner	1	
3	60-1911	Tommy bar	1	
4	60-2084	Spanner — open ended	1	
5	60-0971	Box spanner	1	
6	60-1907	Ring spanner	1	
7	60-0974	Tyre valve key	1	
8	60-0767	Screw driver	1	
9	60-1050	Plug spanner	1	
10	60-3711	Tommy bar, rear wheel spindle	1	
Not illus.	60-2599	Licence holder	Available

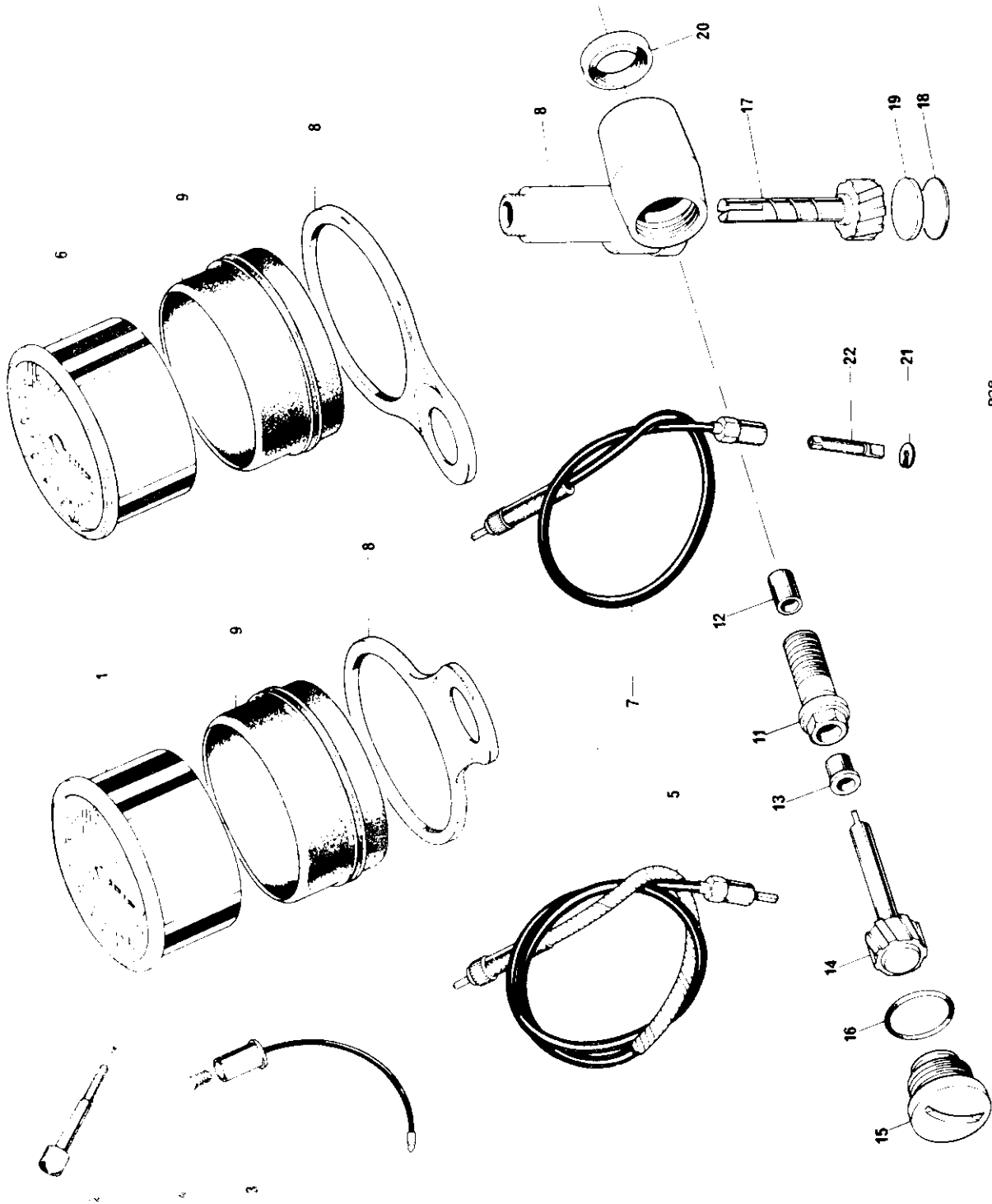

B28

10 TACHOMETER GEARBOX COMPLETE

Fig. 32. SPEEDOMETER AND TACHOMETER

SPEEDOMETER AND TACHOMETER

1	SSM5007/00	Speedometer head (60-2394)	1	
1	SSM5007/01	Speedometer head—KPH (60-2395)	1	Alternative
2	41-148-203-10	Trip control (99-0176)	1	
3	54959626	Bulb holder	1	Reference only
4	643	Bulb (3W.MES)	1	Reference only
5	60-3376	Speedometer cable	1	
6	RSM3003/13	Tachometer head (60-2396)	1	
7	60-3933	Tachometer cable	1	
8	97-4026	Mounting bracket	2	
9	60-2600	Rubber cup	2	
10	71-2475	TACHOMETER GEARBOX	1	
11	70-9332	SECURING SCREW	1	
12	70-5156	Bush	1	Reference only
13	70-5155	Flanged bush	1	Reference only
14	70-5157	Driving gear	1	
15	71-2480	End cap	1	
16	60-3355	'O' ring	1	
17	71-2653	Driven gear	1	
18	71-2481	Welch washer	1	
19	71-2482	Spacer	1	
20	70-7351	Sealing washer	1	
21	60-0494	Circlip	1	
22	31-371-398	Spade (99-0173)	1	
Not illus.	60-2391	Washer	4	Speedo and Tacho mounting
Not illus.	21-0778	Nut		

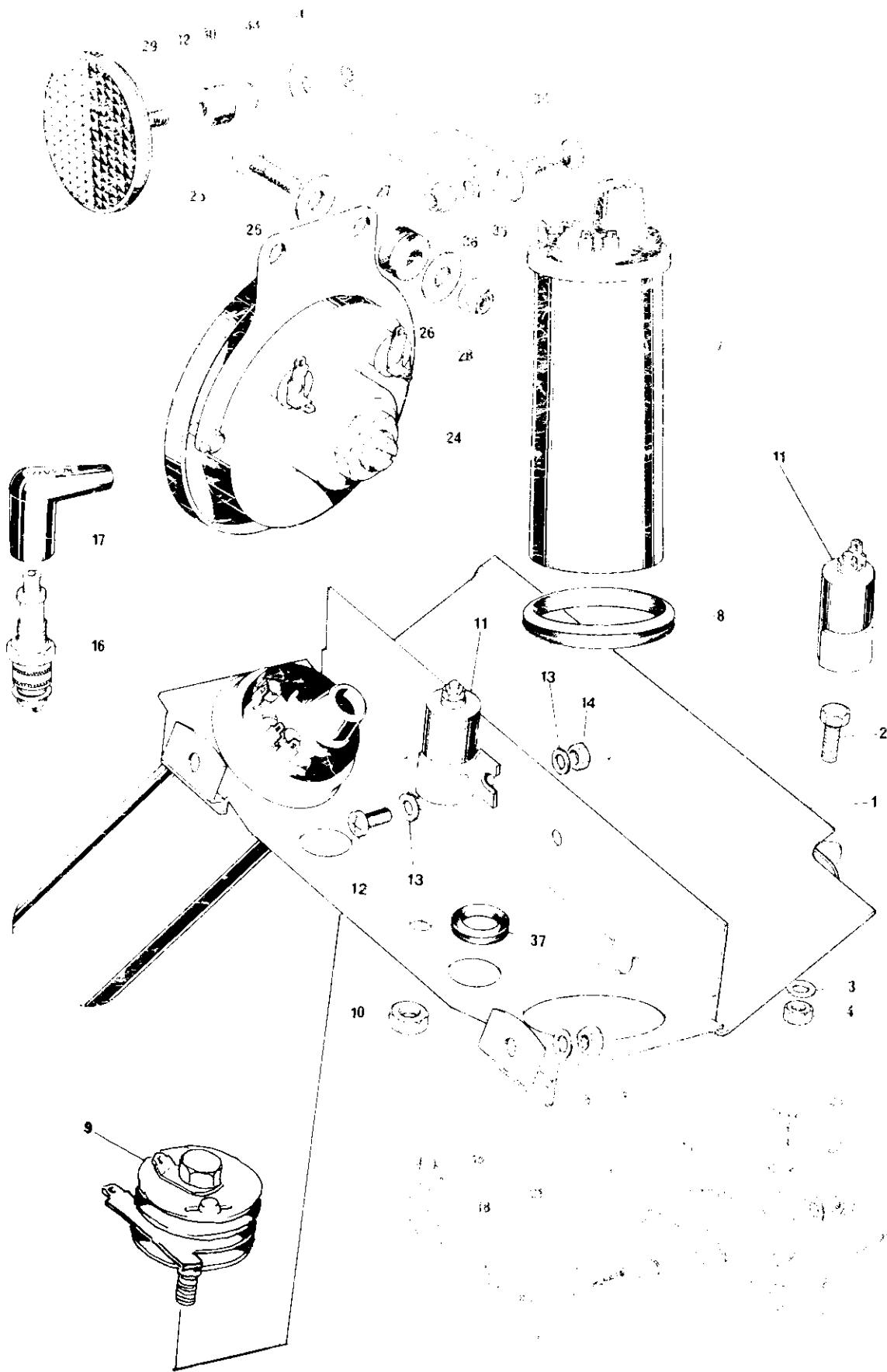

Fig. 33. COIL, CAPACITOR PACK, FLASHER UNIT, ZENER DIODE AND HORN

ELECTRICAL COMPONENTS

1	83-4601	Mounting platform—electrical components	1	
2	14-0102	Bolt	2	
3	60-2329	Washer	2	Mounting platform attachment—rear
4	14-1201	Nut	2	
5	14-1301	Nut	2	Front attachment
6	60-2329	Washer	2	
7	45223	Ignition coil (17-M-12) (60-2203)	2	
8	82-9561	Coil grommet	2	
9	49072	Rectifier (99-0589)	1	
10	82-5338	Nut	1	
11	54441582	Condenser (99-0776)	2	
12	21-2079	Screw	2	Condenser attachment
13	60-2391	Washer	4	
14	21-0778	Nut	2	
15	49345	Zener diode (99-0590)	1	
16	N3	Sparking plug		Reference only
17	60-0262	Plug cover (Champion WC 200)	2	
18	35048	Flasher unit (99-1201)	1	
19	54385091	Clip, flasher unit (99-1204)	1	
20	60-3614	Spring	1	Flasher unit attachment
21	21-2079	Screw	2	
22	60-2391	Washer	3	
23	21-0778	Nut	2	
24	70228	Horn—6H (99-1245)	1	
25	14-0103	Bolt	2	Horn attachment
26	60-2347	Washer	4	
27	60-3161	Grommet	2	
28	14-1301	Nut	2	
29	57183	Reflector—Amber (99-1161)	2	
30	60-2391	Washer	2	Reflector mounting
31	82-4717	Nut	2	
32	83-3522	Mounting rubber	2	
33	83-3764	Reflector bracket	2	
34	21-2120	Bolt	4	Bracket to frame
35	60-2391	Washer	4	
36	21-0778	Nut	4	

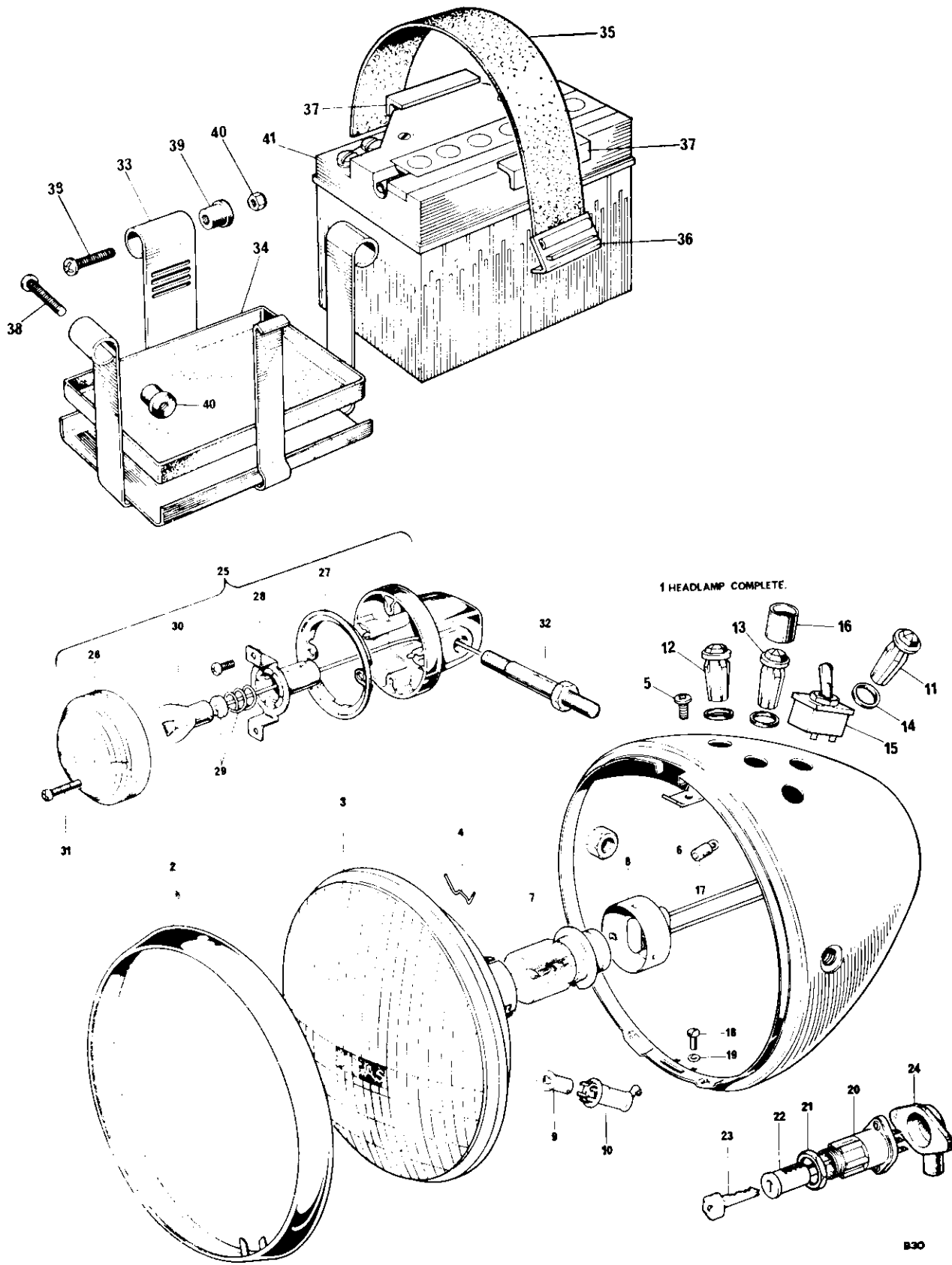

Fig. 34. HEADLAMP AND FLASHER LAMPS

Ref. No.	Part No.	DESCRIPTION	QUANTITY	REMARKS
HEADLAMP AND FLASHER LAMPS				
1	60512	HEADLAMP COMPLETE (99-1267)	1	
2	553248	Rim (99-0692)	1	
3	516801	Light unit (99-1156)	1	
4	504665	Fixing wire (99-0683)	6	
5	144921	Screw		Reference only
6	534296	Plate		Reference only
7	370	Main bulb (45-35W) (99-1214)	1	
8	554602	Bulbholder		Reference only
9	989	Pilot bulb (99-0548)	1	
10	54573590	Pilot bulbholder (99-1213)	1	
11	54363454	Warning light (Red) (99-1208)	1	
12	54363455	Warning light (Green) (99-1209)	1	
13	54363453	Warning light (Amber) (99-1207)	1	
14	54140331	Sealing washer (99-1210)	3	
15	34419	Light switch (99-1251)	1	
16	54525212	Shield, warning light		Reference only
17	281	Bulb, warning light (99-0537)	3	
18	54115106	Screw, headlamp fixing (99-1223)	2	
19	143086	Washer, headlamp fixing (99-1224)	2	
Not illus.	54961593	Wiring harness (99-1259)	1	
20	31899	IGNITION SWITCH (99-0558)	1	
21	54130041	Nut		Reference only
22	82-6981	IGNITION LOCK C/W KEY	1	
23	60-0622	Key (state serial number)		As required
24	97-2262	Cover, ignition switch	1	
25	56147	FLASHER LAMP (99-1190)	4	
26	54581638	Lens (99-1191)	1	
27	54580300	Gasket		Reference only
28	554548	Bulbholder		Reference only
29	573832	Interior assembly		Reference only
30	382	Bulb (99-1192)	1	
31	54123401	Screw (99-1193)	2	
32	60600092	Stanchion, flasher lamp (99-1246)	4	
33	83-3325	Battery carrier	1	
34	82-8091	Carrier tray	1	
35	82-9353	Retaining strap	1	
36	83-3849	Buckle	1	
37	82-7380	Protective strip	4	
38	83-2508	Shoulder screw	3	
39	82-6039	Rubber bush	3	} Battery carrier mounting
40	14-1301	Nut	1	
41	54027029	Battery—PUZ5A (99-0719)	1	

**STANDARD HARDWARE SPECIFICATION
BOLTS**

Part No	Material	Thd. dia.	Length under head	Min. length of thread	Hexagon A.F.
21-1822	Steel	$\frac{5}{16}$ " UNF	$\frac{1}{2}$ "	$\frac{27}{64}$ "	0.500"
21-1910	"	$\frac{3}{8}$ " UNF	$\frac{13}{16}$ "	$\frac{13}{16}$ "	0.565"
21-1919	"	$\frac{5}{16}$ " UNC	$1\frac{3}{8}$ "	$\frac{7}{8}$ "	0.500"
21-2010	"	$\frac{1}{4}$ " UNF	$\frac{13}{16}$ "	$\frac{3}{8}$ "	0.375"
14-0101	"	$\frac{1}{4}$ " UNF	$\frac{1}{2}$ "		0.438"
14-0102	"	$\frac{1}{4}$ " UNF	$\frac{5}{8}$ "		0.438"
14-0103	"	$\frac{1}{4}$ " UNF	$\frac{3}{4}$ "		0.438"
14-0113	"	$\frac{5}{16}$ " UNF	$\frac{5}{8}$ "		0.500"
14-0114	"	$\frac{5}{16}$ " UNF	$\frac{3}{4}$ "		0.500"
14-0115	"	$\frac{5}{16}$ " UNF	$\frac{7}{8}$ "		0.500"
14-0128	"	$\frac{3}{8}$ " UNF	1"		0.563"
14-0208	"	$\frac{1}{4}$ " UNF	$2\frac{1}{4}$ "	$\frac{3}{4}$ "	0.438"
14-0216	"	$\frac{5}{16}$ " UNF	$1\frac{1}{8}$ "	$\frac{7}{8}$ "	0.500"
14-0217	"	$\frac{5}{16}$ " UNF	$1\frac{1}{4}$ "	$\frac{7}{8}$ "	0.500"
14-0219	"	$\frac{5}{16}$ " UNF	$1\frac{1}{2}$ "	$\frac{7}{8}$ "	0.500"
14-0220	"	$\frac{5}{16}$ " UNF	$1\frac{3}{4}$ "	$\frac{7}{8}$ "	0.500"
14-0225	"	$\frac{5}{16}$ " UNF	3"	$\frac{7}{8}$ "	0.500"
14-0228	"	$\frac{5}{16}$ " UNF	4"	$\frac{7}{8}$ "	0.500"
14-0234	"	$\frac{3}{8}$ " UNF	$1\frac{3}{4}$ "	1"	0.563"
14-0236	"	$\frac{3}{8}$ " UNF	$2\frac{1}{4}$ "	1"	0.563"
14-0239	"	$\frac{3}{8}$ " UNF	3"	1"	0.563"
14-0240	"	$\frac{3}{8}$ " UNF	$3\frac{1}{4}$ "	1"	0.563"
14-0242	"	$\frac{3}{8}$ " UNF	4"	1"	0.563"
14-0251	"	$\frac{7}{16}$ " UNF	$2\frac{3}{4}$ "	$1\frac{1}{4}$ "	0.625"
14-6102	"	$\frac{1}{4}$ " UNC	$\frac{5}{8}$ "		0.438"
14-6115	"	$\frac{5}{16}$ " UNC	$\frac{7}{8}$ "		0.500"

NUTS

Part No.	Material	Thd. dia.	Hexagon A.F.	Thickness	Remarks
21-0778	Steel	No. 10 UNF	0.375"	0.225"	Cleveloc
21-1852	"	$\frac{5}{16}$ " UNF	0.437"	0.330"	Philidas
21-1906	"	$\frac{1}{4}$ " UNF	0.438"	0.188"	Plain
21-1908	"	$\frac{5}{16}$ " UNF	0.438"	0.313"	Plain
21-1914	"	$\frac{3}{8}$ " UNF	1.125"	0.250"	Plain
21-2012	"	$\frac{7}{8}$ " UNF	1.313"	0.438"	Plain
21-2013	"	$\frac{3}{4}$ " UNF	1.313"	0.313"	Plain
21-2014	"	$\frac{3}{4}$ " UNF	1.313"	0.438"	Plain
14-0301	"	$\frac{1}{4}$ " UNF	0.438"	0.224"	Plain
14-0302	"	$\frac{5}{16}$ " UNF	0.500"	0.271"	Plain
14-0401	"	$\frac{1}{4}$ " UNF	0.438"	0.161"	Lock
14-0402	"	$\frac{5}{16}$ " UNF	0.500"	0.192"	Lock
14-0403	"	$\frac{3}{8}$ " UNF	0.563"	0.224"	Lock
14-0701	"	$\frac{1}{4}$ " UNF	0.438"	0.203"	Philidas
14-0702	"	$\frac{5}{16}$ " UNF	0.500"	0.246"	Philidas
14-0703	"	$\frac{3}{8}$ " UNF	0.563"	0.296"	Philidas
14-1201	"	$\frac{1}{4}$ " UNF	0.438"	0.285"	Stiffnut
14-1202	"	$\frac{5}{16}$ " UNF	0.500"	0.335"	Stiffnut
14-1301	"	$\frac{1}{4}$ " UNF	0.438"	0.245"	Stiffnut
14-1302	"	$\frac{5}{16}$ " UNF	0.500"	0.290"	Stiffnut
14-1303	"	$\frac{3}{8}$ " UNF	0.563"	0.320"	Stiffnut
14-1304	"	$\frac{7}{16}$ " UNF	0.688"	0.375"	Stiffnut
14-1305	"	$\frac{1}{2}$ " UNF	0.750"	0.435"	Stiffnut
14-1902	"	$\frac{5}{16}$ " UNF	0.500"	0.361"	Nyloc
14-1903	"	$\frac{3}{8}$ " UNF	0.563"	0.375"	Nyloc

SCREWS

<i>Part No.</i>	<i>Type of head</i>	<i>Material</i>	<i>Thd. dia.</i>	<i>Length under head</i>	<i>Type of drive</i>
21-1916	Cheese head	Steel	$\frac{1}{4}$ " UNC	$1\frac{1}{8}$ "	Cross recess
21-1917	Cheese head	"	$\frac{1}{4}$ " UNC	$2\frac{5}{8}$ "	Cross recess
21-1918	Cheese head	"	$\frac{1}{4}$ " UNC	$2\frac{3}{8}$ "	Cross recess
21-1920	Hex. head	"	$\frac{1}{4}$ " UNC	$2\frac{1}{64}$ "	
21-1929	Countersunk (82°)	"	$\frac{1}{4}$ " UNC	$\frac{17}{32}$ "	Slot
21-2079	Cheese head	"	No. 10 UNF	$\frac{1}{2}$ "	Pozidrive
14-0604	Cheese head	"	$\frac{1}{4}$ " UNF	$\frac{1}{2}$ "	Cross recess
14-6505	Countersunk (82°)	"	$\frac{1}{4}$ " UNC	$\frac{7}{8}$ "	Cross recess
14-6607	Cheese head	"	$\frac{1}{4}$ " UNC	$\frac{7}{8}$ "	Cross recess
14-6608	Cheese head	"	$\frac{1}{4}$ " UNC	1"	Cross recess
14-6609	Cheese head	"	$\frac{1}{4}$ " UNC	$1\frac{1}{4}$ "	Cross recess
14-7019	Socket head	"	$\frac{5}{16}$ " UNC	$\frac{7}{8}$ "	Hex. socket
14-7024	Socket head	"	$\frac{5}{16}$ " UNC	2"	Hex. socket

WASHERS—PLAIN

<i>Part No.</i>	<i>Material</i>	<i>i/dia.</i>	<i>o/dia.</i>	<i>Thickness</i>
60-4245	Steel	0.273"	0.563"	0.048"
60-4246	Steel	0.398"	0.750"	0.063"
60-4247	Steel	0.336"	0.625"	0.063"
37-2027	Steel	0.531"	1.031"	0.092"
60-4248	Steel	0.266"	0.469"	0.064"

WASHERS—SPRING

<i>Part No.</i>	<i>Material</i>	<i>i/dia.</i>	<i>o/dia.</i>	<i>o/a height</i>	<i>Thickness</i>
60-4259	Spring Steel	$\frac{3}{8}$ " clearance	$\frac{13}{32}$ "	$\frac{7}{32}$ "	0.104"
60-4250	" "	$\frac{1}{4}$ " clearance	$\frac{13}{32}$ "	$\frac{1}{16}$ "	0.064"
60-3541	" "	$\frac{17}{32}$ "	$\frac{7}{8}$ "	$\frac{7}{32}$ "	0.040**
21-0648	" "	$\frac{5}{16}$ " clearance	$\frac{1}{2}$ "	$\frac{5}{32}$ "	0.080"

** Double coil.